



Clarion

THE CANADIAN REFORMED MAGAZINE

Volume 27, No. 4

February 25, 1978



The False Prophecy of Hal Lindsey

The Seven-Year Advent (IV)

A. A LITTLE REVIEW

Last time we examined the dispensational teaching of the 1000-year reign of Christ over this world from His throne in earthly Jerusalem. After thorough investigation, such as made by Rev. Tj. Boersma in *De Bijbel is geen puzzelboek*, we concluded that there is no Scriptural foundation at all for such prophecy. Instead we live in that period symbolically called "1000 years" today. Christ sits on the throne in heaven today already.

The literal approach to prophecy which often uses symbols, signs, dreams, and visions hampers Hal Lindsey and this school of prophecy. Weird explanations occur as a result, as we will see in this article.

For, if you still have the second article in this series handy, Diagram I will show another important time period of dispensationalism. It is called the Great Tribulation. It consists of seven years during which prophecy unfolds in an alarming, dramatic, and electrifying pace. But do not be afraid about yourselves if you are a believer, says Lindsey. For Christ will snatch his saints off the earth (the rapture) before this period of the great tribulation starts. You will not need to experience the atrocities of this time. You will be in heaven. Look at Diagram 1 again. In a future article we hope to examine the teaching about the rapture.

B. HAL LINDSEY EXPLAINS THE SEVEN-YEAR PERIOD

Let us give the floor to Hal Lindsey first. In his book, *The Late Great Planet Earth*, he explains the seven-year period as follows in Chapter Four, entitled "Israel, O Israel!":

Some time in the future there will be a seven-year period climaxed by the visible return of Jesus Christ. Most prophecies which have not yet been fulfilled concern events which will develop shortly before the beginning of and during this seven-year countdown. The general time of this seven-year period couldn't begin until the Jewish people re-established their nation in their ancient homeland of Palestine.

The one event which many Bible students in the past overlooked was this paramount prophetic sign: Israel had to be a nation again in the land of its forefathers. Israel a nation — a dream for so many years, made a reality on 14 May,

1948 when David Ben-Gurion read the Declaration of Independence announcing the establishment of a Jewish nation to be known as the State of Israel. In 1949, Prime Minister Ben-Gurion said that Israel's policy "consists of bringing all Jews to Israel . . . we are still at the beginning."

When the signs just given begin to multiply and increase in scope it's similar to the certainty of leaves coming on the fig tree. But the most important sign in Matthew has to be the restoration of the Jews to the land in the rebirth of Israel. Even the figure of speech "fig tree" has been a historic symbol of national Israel. When the Jewish people, after nearly 2000 years of exile, under relentless persecution, became a nation again on 14 May 1948 the "fig tree" put forth its first leaves. Jesus said that this would indicate that He was "at the door," ready to return. Then He said, "Truly I say to you, *this generation* will not pass away until all these things take place" (Matthew 24:34 NASB). What generation? Obviously, in context, the generation that would see the signs — chief among them the rebirth of Israel. A generation in the Bible is something like forty years. If this is a correct deduction, then within forty years or so of 1948, all these things could take place. Many scholars who have studied Bible prophecy all their lives believe that this is so.

The main points are these: first, there will be a reinstatement of the Jewish worship according to the law of Moses with sacrifices and oblations in the general time of Christ's return; secondly, there is to be a desecration of the Jewish Temple in the time immediately preceding Christ's return. We must conclude that a third Temple will be rebuilt upon its ancient site in old Jerusalem.

With the Jewish nation reborn in the land of Palestine, ancient Jerusalem once again under total Jewish control for the first time in 2600 years, and talk of rebuilding the great Temple, the most important prophetic sign of Jesus Christ's soon coming is before us. This has now set the stage for the other predicted signs to develop in history. It is like the key piece of a jigsaw puzzle being found and then having the many adjacent pieces rapidly fall into place. For all those who trust in Jesus Christ, it is a time of electrifying excitement.

Lindsey indeed condenses many prophetic, "apocalyptic" events into this compact period. But this is not all. Also included in this seven-year advent are the following:

1. Israel's covenant with hell. A Roman

prince, leading the European Common Market nations, makes a covenant with Israel. He shall allow the temple to be rebuilt and the old covenant to be reinstated. All will worship this fuehrer, the antichrist. Then he will make a turnabout and declare himself to be god in the temple where he will take his seat.

2. Middle East Conflict ending in the great battle of Armageddon. This conflict has five phases. Phase one is the African-Arabian attack on Israel (Dan. 11:40). Phase two is the Russian (Gog!) amphibian and land attack on Israel (Dan. 11:40 and Ezek. 38). In phase three Russia turns traitor against Egypt, the most important nation in the United Arab Republic (Dan. 11:42, 43). During phase four when Russia invades Africa, an alarm from the east (armies from the east) and north (Roman armies) cause Russia to retreat to Israel. During phase five the Roman antichrist with all his allies will utterly destroy Russia (Ezek. 38:18-22; 39:3-5).

3. Armageddon. This leaves the united forces under the command of the Roman dictator and the vast hordes from the east (Rev. 16:12). These are the Chinese, "The Yellow Peril," who will come 200 million strong. The battles center in Armageddon, the valley of Megiddo. Jerusalem shall witness a bloodbath (Zech. 12:10-14; Rev. 14:20).

4. Jesus appears as Messiah to the Jews. A mass conversion of the Jews will occur. A fountain of forgiveness will open and Jesus will return in triumph to Jerusalem (Zech. 14:1-21). Thus the 1000 years start.

This brief sketch of a complicated, intricate scheme of bible-interpretation gives you some idea of the direction and style of Hal Lindsey and the dispensationalists.

C. EXAMINATION OF THE SEVEN-YEAR ADVENT OF HAL LINDSEY

Understandably, we cannot go into details about all these points. Then we, too, must write a book. And "one fool can ask more question than seven wise men can answer." Therefore we recommend the books by Tj. Boersma and C. van der Waal, *En het zal geschieden in de laatste dagen . . .* Especially Tj. Boersma has patiently and thoroughly tested each tenet of this whole teaching, taking each aspect chapter by chapter and examining it in the light of the Scriptures themselves. C. van der Waal takes a more thematic

approach, limiting his remarks mainly to the explanation and interpretation of the Book of Revelation. Both are extremely worthwhile. Thankfully, we can expect a translation of the first book in the near future.

C. van der Waal quotes Article XIX of the Doctrinal Statement of the Dallas Theological Seminary in Dallas, Texas (center of dispensationalism and the place where Lindsey received his training):

We believe that the translation of the church [the rapture, W.H.] will be followed by the fulfilment of Israel's seventieth week (Dan. 9:27; Rev. 6:1-19:21) during which the church, the body of Christ, will be in heaven [pretribulationism, W.H.]. The whole period of Israel's seventieth week will be a time of judgment on the whole earth, at the end of which the times of the Gentiles will be brought to a close. The latter half of this period will be the time of Jacob's trouble (Jer. 30:7), which our Lord called the great tribulation (Matt. 24:15-21). We believe that the universal righteousness will not be realized previous to the second coming of Christ, but that the world is day by day ripening for the judgment and that the age will end with a fearful apostasy.

He summarizes it as follows:

- The time after the church-age is the seventieth week of Daniel. The church has disappeared from earth at that time.
- Rev. 6-19 refers to this time. The church is not mentioned in this part of Scripture.
- The Great Tribulation takes place 3 ½ years after the close of the church-age.
- The world becomes steadily worse and ends up in a terrible apostasy in the end-time.

He then examines each point and finds each point "weighed and found wanting."

D. WHY SEVEN YEARS?

As the quote from Lindsey makes clear, reference is made to Revelation 11:2, 3:

And leave out the court which is outside the temple, and do not measure it, for it has been given to the nations; and they will tread under foot the holy city for forty-two months. And I will grant authority to my two witnesses, and they will prophesy for twelve hundred and sixty days, clothed in sackcloth.

Three and a half years are simply added to 1260 days (three and a half years) to come to a seven-year period. Into this short time God packs all those "unfulfilled" prophecies. Connected with this is the dispensational interpretation of Daniel 9:24:

Seventy weeks have been decreed for your people and your holy city, to finish the transgression, to make an end of sin,

to make atonement for iniquity, to bring in everlasting righteousness, to seal up vision, and prophecy, and to anoint the most holy place.

Lindsey reckons a week as a week of years (not exactly literal!), i.e., $70 \times 7 = 490$ years. Then he starts figuring dates. From the return from Babylon to the coming of the Messiah 69 weeks of years pass, i.e. 483 years go by. One week (seven years) remains. These seven years are postponed because the Jews rejected the Messiah and God turns to the Gentiles for a time (the church-age). At the end of the church-age God turns His attention back to the Jews and the time-clock of prophecy starts to tick again. Then all that is revealed in Revelation 6-19 unrolls as a film before your eyes in this short seven years. Now the countdown begins. Seven years and then the Christ appears! It is an advent season.

But is this right? We answer with a ringing "no"! The three and a half years or 1260 days or times (two times), time and half a time or 1000 years are expressions used in Revelation to point to one and the same period of time: the New Testament era from Christ's fulfilled ministry till just before His coming in glory. Read W. Hendriksen's *More Than Conquerors*, Baker, 1963, p. 173ff., on the interpretation of this, for example, to confirm this conclusion. C. van der Waal and Boersma conclude the same. Three and a half years clearly refers to an important Old Testament period. It was one of affliction, persecution, apostasy, and also one in which was demonstrated the power of His Word. Therefore Jesus uses it for the sake of encouraging and stimulating His churches. We refer to the time of Ahab and Elijah. As James says,

Elijah was a man with a nature like ours, and he prayed earnestly that it might not rain; and it did not rain on the earth for *three years and six months* [emphasis is mine, W.H.].

All these expressions of time come from the Old Testament to *characterize* the time about which John writes but *not* to give definite time references. The contents of the visions do that.

Moreover, in Daniel 9 the historical references are to the wars which took place between the two testaments and do not refer to the end-time as Lindsey claims (Boersma clarifies this in his book, Chapter 11). Again, the dispensational student has simply

clipped out texts (Jeremiah 30:7, about Jacob's trouble, too; along with Matthew 24:15-21, which speaks about the Jews in the days of Jesus) completely out of their context and pasted them alongside one another. It may provide exciting reading, but it is inexcusable manipulation of the Holy Scriptures and pure deception. That perfect parable about the fig tree which we quoted is so childish and laughable that we do not need to refute it for Reformed readers. To convince you of the untenable nature of such interpretation of prophecy we hope to zero in on one phase of this seven-year period, "The Yellow Peril," next time. Till then.

W. HUIZINGA



THE CANADIAN REFORMED MAGAZINE

Published bi-weekly by Premier Printing Ltd.
Winnipeg, Manitoba.

Second class mail registration number 1025.

ADDRESS FOR ADMINISTRATIVE MATTERS: (subscriptions, advertisements, etc.):

CLARION, Premier Printing Ltd.
1249 Plessis Road, Winnipeg,
Manitoba, Canada R2C 3L9
Phone (204) 222-5218

ADDRESS FOR EDITORIAL MATTERS:

CLARION
P.O. Box 54, Fergus,
Ontario, Canada N1M 2W7

EDITORIAL COMMITTEE

Editor: W.W.J. VanOene
Co-Editors: J. Geertsema, Cl. Stam,
D. VanderBoom

SUBSCRIPTIONS:

\$19.50 per year (to be paid in advance).

ISSN 0383-0438

IN THIS ISSUE

The False Prophecy of Hal Lindsey (4)	
— W. Huizinga	74
Press Review — J. Geertsema	76
Circumspection — Cid	77
School Crossing — J.J. Kuntz	79
Meditation — Aliens and Exiles, You Are God's Own People — J. Van Rietschoten	80
King Solomon's Molten Sea (4)	
— A. Zuidhof	82
News Medley — W.W.J. VanOene	84
Ordination and Installation of Rev. E.J. Tiggelaar	86
International — Cl. Stam	87
Mission News — Bram and Joanne Vegter	88
Farewell to Rev. H. Versteeg	89
A Corner for the Sick — Mrs. J.K. Riemersma	90
Letters-to-the-Editor — J. Vanderstoep	90
Food: Facts and Fallacies — J. Vanderstoep	91
Our Little Magazine — Aunt Betty	92

press review

GRACE CONTRA TRADITION??

In *Vanguard*, an independent magazine connected with the AACS (the Association for the Advancement of Christian Studies) in Toronto, a column regularly appears under the name, "Take hold of God and pull." It is of a meditation character. In the September/October 1977 Issue, Mr. Hendrik Hart writes in this column about "Schooled in Grace." He starts by saying that:

a call to order based on God's Word is likely to imply a critical attitude toward tradition and history.

The guide for this critical attitude, of course, must be the Bible. He finds this guide in an excellent way in Acts 15.

The reader knows the story. Paul and Barnabas have come back from their first missionary journey. In the sending Church at Antioch, however, there are members who have some objections against Paul's work. He should teach the believers from the Gentiles that they, too, have to be circumcized: "It is necessary to circumcize them, and to charge them to keep the law of Moses," otherwise they cannot be saved, they said (verses 1 and 5).

Paul and Barnabas then were sent to Jerusalem. There a meeting was held. Peter spoke there about what the LORD had done through Him: how He had sent him to the Gentiles; and that they had received the Holy Spirit without being circumcized first. He added that they should not try God by putting a yoke on the neck of the believers that also the Jews could not bear. God does not make a distinction. So we may not do it either. Both Jew and Gentile are saved by Christ.

After Paul and Barnabas had related the work of the Lord through their hands among the Gentiles, James spoke and pointed to the promises of God in the Old Testament. He said they should not trouble the Gentiles, but tell them to keep some rules for their life in faith in Christ: abstain from the pollution of idols and from unchastity, from what is strangled and from blood. They decided accordingly.

In relating this story the author of the article, Mr. Hart, says that in Acts 15:

certain traditionalists wanted the historic sacrament of God's people (circumcision) as well as the law of Moses retained for new converts. We *must* not judge these folks too harshly. Their tradition was not, as is ours, mostly the result of the leadership of pious men (Luther, Wesley, Calvin, Kuyper, etc.) or of the influence of confessions written by people (Belgic, Dordt, Westminster, etc.), but the immediate and direct leadership of the Lord had been at the bottom of their ways of life.

One could ask the question: What does the writer mean by this word "tradition"? Is that the Old Testament Word of God? Or is it the way of teaching of the Scribes and Pharisees, who in many cases wrested the Word of the LORD and who found in Christ a strong opponent? If the latter is meant, I do not have so much objection against the word "tradition" here. But if the written Old Testament Word of the LORD is meant, or if Mr. Hart is vague here because for him there is not much difference between the two in this case, then I disagree completely.

Yet, let us assume for a moment that the Pharisees' explanation of the law of the LORD is meant. Then, however, I have to disagree with the above-quoted comparison between the "tradition" as coming from Luther and Calvin, etc., and as founded in the Confessions, and the "tradition" in the days of the apostles as coming from the Pharisaic teachers of the law. Then, I would say: the tradition of the Pharisees was clearly shown by Christ to be wrong. But the Reformed Confession is fully Scriptural. Or is it not?

However, on the very basis of this comparison, as well as of the fact that about that "tradition" in the days of Paul it is said that "the immediate and direct leadership of the Lord had been at the bottom" of it, and since the matter at issue is the law of Moses as such and the sacrament of circumcision, I can only conclude that Mr. Hart also means the written Old Testament Word of God when he speaks about "tradition." That is the way also Pro-

fessor Dr. H.M. Kuitert at the Free (Liberal) University in Amsterdam speaks about the Word of the LORD. But talking about a "tradition at whose bottom the direct and immediate leadership of the Lord has been" is too vague a way of speaking for one who wants to be Reformed, as far as I can see. A liberal-thinking person who does not believe the infallibility and inerrancy of Holy Writ can fully agree with this vague way of speaking.

But there is more. In relating what Peter spoke at the meeting in Jerusalem the writer says that the apostle:

stresses that in these matters the Spirit is of prime importance and that all believers do have the Spirit, not just those who keep the tradition. One can trust the Spirit (who leads into all truth) to help a people shape their own tradition . . . no tradition has any power to save. All of us . . . will be saved by grace.

It is true: we are saved by grace, but in the way of a true faith, which makes us live in obedience by what is written, keeping the commandments of the Lord.

Mr. Hart, coming with his conclusion from this chapter of the Bible, writes:

This event, as recorded in Acts 15, provides a lot of material for us in coming to grips with the problems of tradition. The most important of these is that life in Christ is a life of living out of grace to which no tradition can lay claim. The crux of traditionalism is that it denies the gospel of grace.

Must we now conclude from this first lesson that holding on and binding each other to a certain "tradition," let us say: to the Reformed Confessions, is opposed to and even denying the gospel of grace?

We continue with the second lesson.

Next to that it is important to realize the leadership of the Spirit of God in fulfilling Joel's famous prophecy . . . For people of reformed and calvinistic traditions the Holy Spirit remains an enigma. He goes where He wills (John 3), which is a very un-reformed thing to do. But when the leaders in Jerusalem want to be schooled in the grace with which they and all other people are saved, they take council with the Holy Spirit.

So, not only can "tradition" and grace be each other's opposite, but also "tradition" and the Holy Spirit. It is on this point that the writer goes on. I give a few more quotations:

Where tradition is the element of conflict . . . they [the meeting in Jerusalem, J.G.] accept the leadership of the Spirit . . .

Continued on page 78.

“DEATH OF A YPS” (III)

We noted last time that the general situation of (some of) our Young People's Societies does not seem to be so good. Key words were: lack of leadership, interest, and cooperation. And we asked the questions, “What is the cause? Where lies the cure?”

Now it is easier to ask these questions than to answer them. And in this article I certainly will not pretend to have and give all the answers. But it might help to bring certain aspects to mind which might influence the positive upbuilding of society life. I have tried to narrow it down to two things: attitude and/or organization. It can be a matter of one or both.

I am not one to blame the structures and overlook the people who make the structures. For decades our societies have functioned quite well as they were. So, I fear, it is mostly a matter of attitude.

It would be a mistake to think that we and our children are quite immune to the “spirit of the times.” Many of us are at least partial victims of the revolutionary spirit of the past decades, which is systematically dismantling established values and bringing about rapid changes. This might account for much of the aggressiveness of some young people. Combine this with a good measure of currently prevailing materialism, and it is clear that much spiritual life is not of sound and deep quality. This might account for much of the indifference of some young people to matters of faith and church.

These acts of aggressiveness and this show of indifference are indicative of many underlying questions and frustrations. Can our young people really keep up with the rapid pace of life and cope with the many tensions of our times? We tend to wonder if the older people can keep stride, but what about our youth? I have the impression that some of our young people are downright afraid of the implications of a committed Christian life in this age, and are masking their insecurity by a false indifference. The kids with the biggest mouths are often the most afraid, I've been told.

Is it true that in our time, when the veils have been removed from many “mysteries,” and when science and technology can “explain” all things, the foundations of our Christian society are shaking? Someone once said to me, “Nowadays kids grow up too soon. There are no

Circumspection...

mountains unconquered, no islands undiscovered; it has all been done.” Has much of the excitement been taken out of youth? Growing up too quickly results in lack of true stamina.

The question is: Are these frustrations being met adequately by parents, teachers, and pastors? And teachers and pastors, of course, are wholly dependent on the coopera-

tion of parents, who have the prime responsibility. Is there a loving and open communion in the homes, where the service of the Lord is taught and lived as a priority, where the joy of salvation in Jesus Christ truly prevails in every activity? I have written on this matter before, but this does seem to be the main question, since basic attitudes are shaped in the homes.

Perhaps some parents cannot give guidance in these things because they themselves are victims of the immigration years, when, with some, work and not study received prime emphasis. Perhaps some parents do not give guidance because they are totally occupied with establishing a solid financial basis for themselves. This, of course, will reflect in the attitudes of young people. Let everyone examine himself.

Teachers and preachers will have to face this aggressiveness and indifference squarely. To add a pinch of salt, blessed are those who meet these attitudes head-on with strong teaching and powerful preaching, with a positive confidence which does not bypass the issues of the times, but stimulates and activates the youth to a vibrant service of God! Parents, teachers, and pastors should be quite honest with each other, open for one another, laying out the difficulties fairly, forming a united front and giving one effort. This would again bring some real life to struggling societies and the enthusiasm would certainly rub off on our young people.

At a meeting of a local school society I recently attended, some parents complained about the attitudes of their teenaged kids. Staff-members in turn complained somewhat about the attitudes of some parents. But let us stop complaining and accusing. The youth of the covenant need to know that all indifference and aggressiveness is met with the power of the Gospel.

Let upbringing, teaching, and preaching be geared to meet this great challenge confidently and warmly in the strength of the Spirit.

Cid

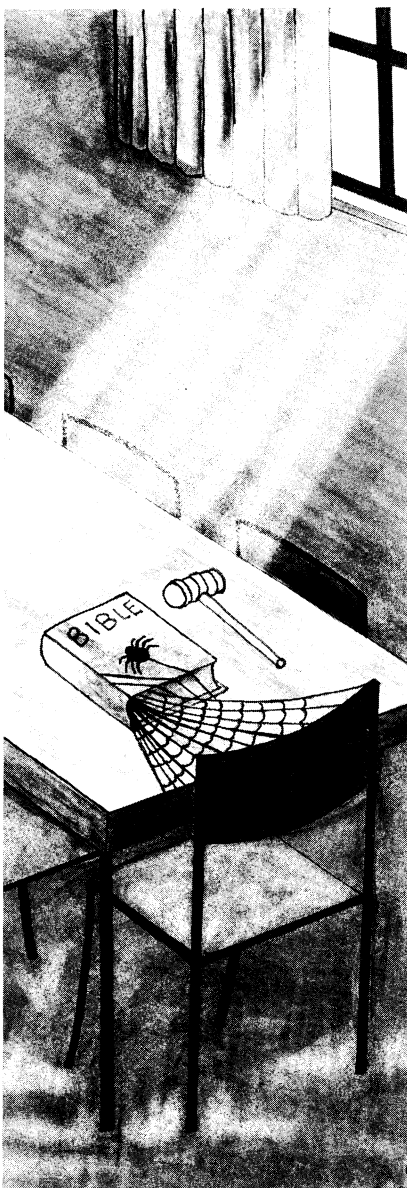

PRESS REVIEW — Continued.

They realise that their own traditions . . . will be a burden to new believers whose background is so totally different. Gracefully they take distance of their traditions For them to refrain from laying their convictions on new believers is an utterly astounding testimony to their Spirit-matured sanctity They showed among other things that they were not only able to distinguish between the traditions of the world and those of believers, but also that they were able to *relativise traditions commanded by God Himself* [Italics mine, J.G.].

The trauma of the tradition problem is that the New Testament calls all of us to have the courageous trust of the Jerusalem council. And the spirituality required for that is simply absent. We can only win the battle against ourselves, I believe, if we willingly submit to the Spirit, who may wish to go ways with us that we do not recognize.

This was the end of the meditation. Dr. Hart will probably say, in reply to my reaction, that it shows exactly that absence of the required spirituality. So be it. But I see this way of explaining and applying the Word of the LORD as both dangerous and wrong.

It is wrong. For the uniqueness of the situation of Acts 15 is not seen. Dr. Hart makes that situation into something which is true for all times. But the (indeed) enormous change that took place in those days, was the change from the Old into the New Testament period; or: from the Old into the New Covenant. And this New Covenant period on this earth will not change again until the return of the Lord. Old and New Testament speak about this enormous change: in the prophecies of Jeremiah and in Hebrews we can read this with so many words. But the Bible does not speak about a continual change. So in Acts 15 we do not find a *relativizing* of certain traditions at all! We have a total, but unique change in covenant-dispensation. And, therefore, the conclusion that we must learn to relativize our New Testament "traditions," and so let ourselves be guided by the Spirit, can not truly be based on what we read in Acts 15. It is first read into it, and then taken from it.

The interpretation given us in this meditation is also dangerous, in my opinion. Dr. Hart places the Holy Spirit over against what he calls tradition, and in that context says that the leaders in Jerusalem "were able to relativize traditions commanded by God Himself," and that "for people of reformed and calvinistic tradition the

Holy Spirit remains an enigma," since the Spirit "goes where He wills (John 3), which is a very unreformed thing to do." If I now would accept this teaching of Dr. Hart, what would I do? I would relativize in the first place, my Reformed tradition; this means: the Reformed Confessions. And I could also even relativize the written Word of the LORD, while claiming to be guided by the Holy Spirit.

And it is exactly this that we see and read liberal Christians do: they go their own ways and come with their own interpretations of Scripture which — as they see it — is in the first place a human, fallible word, that was time-bound and culture-bound. In that way, revolution, women in ecclesiastical office, justification of divorce, even homosexuality, and many more things, which the Bible calls sin, are made acceptable.

It is exactly in this way, of placing the guidance of the Spirit over against confessions, that the modern neo-Pentecostal movement teaches and preaches Christian unity and salvation: Confessions divide, but the Spirit unites, they claim. And thus, in their view, one can be guided by the Holy Spirit, and, e.g., be fully Roman Catholic, and revere Mary and pray to her, etc., at the same time. But this would mean: the Holy Spirit guides a person to go against the very Word of the Spirit.

I hear in this article of Mr. Hart this modern way of speaking about the Spirit and His guidance, which is a cover for justifying one's own ways in conflict with the written Word and confessed truth of our God. Is it so that under the influence of this way of thinking and speaking, the A.A.C.S. becomes more and more liberal? The Holy Spirit binds us to the written Word of God, and to that Word as it is written. He binds the believers to the truth of the Word of God: to the truth as we confess it in our Three Forms of Unity. For those Standards are not important in themselves. They are important because they are the confession of the truth of God's Word. Binding to the Confessions means nothing but binding the Churches to the very truth of God's Word. It is therefore fighting the good fight. The history of the Church has shown more than once that relativizing the confessions goes together with relativizing or denying certain truths of the Scriptures, and that it brings along the deviation of the Church from the truth. That is what

happened with the Remonstrants in the beginning of the 1600's.

I have a question. The philosophy of law sponsored by the A.A.C.S. speaks of the three forms of the Word of God: the Word of creation, the Word incarnate (in Christ), and the Word inscripturated (the Bible). And, if I understand it well, these three forms of God's Word are to be placed on the same level. Is it now so that what we find in creation as the laws of creation in the several different spheres of life, is of the same value as the written Word of God? And if this is so, is the big mistake not made here already? When we search the spheres of life and find certain laws, we cannot place those creation-laws (like the troth-law for marriage) on one level with God's written Word. Scripture is the infallible, inerrant, inspired Word of God. With creation-laws it is different. In the first place, through the fall into sin God's curse came on His creation, and, more important yet, our human mind is not perfect anymore, but inclined to evil; and thus the laws that we find and formulate are fallible and not inspired truth as the Word of the LORD is. Therefore we cannot place them on the same level.

Besides, the Word of God with which He created all things is different from the Word of God revealing to us the truth about God and His creation. Now my question is: Is this way of speaking about the three forms of God's Word at the bottom of the way of speaking about grace, Spirit, and tradition as it is done in the article discussed above?

It is my wish that the A.A.C.S. will return to the truly Reformed "tradition," that means: to the binding to the Reformed Confessions. But if the way of thinking, the philosophy, as it appears from this "meditation" of Dr. Hart is characteristic of the A.A.C.S., I fear that it will completely end up in liberal and/or Neo-Pentecostal waters. And that is, then, the result when we place our findings (the laws we find in creation) on one level with (which practically means: above) the written Word of the LORD, and instead of building the Kingdom of Christ, which is the intention, it is broken down. It is sad; it is a pity. The claim that Christ is Redeemer of the whole of creation and that He therefore must be acknowledged as King over and in all aspects and spheres of life, is so Scriptural. But Christ binds us to His written Word *as it is written*. J. GEERTSEMA

school crossing

OPENING OF THE COVENANT CANADIAN REFORMED SCHOOL OF NEERLANDIA

There is an old yellow schoolbus making its daily rounds along highways 18 and 44 in western Alberta. It needs repairs to its worn engine which is leaving a trail of oil from Barrhead to Neerlandia and back again, but that will have to wait till summer. It can't be missed right now for it is the only transportation available to students at the *Covenant Canadian Reformed School of Neerlandia*. Scarred and scored with age, carefully driven by Mr. J. Holwerda, it faithfully delivers its young passengers into the care each day of



Dr. P. VanBostelen presents the Chairman, Mr. P. Werkman, with a book.

Mr. J.J. Hoekstra, the Principal at the school.

Not many ever visit this region of Alberta with its two small congregations. Out of the way, isolated in many respects, it offers few attractions to the visitor. A tourist guide of Alberta mentions only that Barrhead has a Centennial Museum and lists as its prized possessions two 300 year old vases, a gristmill, a fireplace, a century old wedding dress and a hand powered vacuum cleaner (c. 1909). The guide makes no mention of Neerlandia at all. There are no performing whales or mind-numbing midways. There the thunder of great waterfalls and the culture of great art collections will not be found. And it is unlikely that the esta-

ishment of the Covenant School will turn that area into a tourist attraction. Yet the opening of that school far surpassed in importance the pomp and circumstance of the ostentatious opening of a multi-million dollar art gallery or some new amusement park where creation and culture fail to rise above the ring of cash registers. For something great did happen in Neerlandia, which should have at least this effect that it reminds us that so often in the history of God's people the greatest things happen in a quiet way and in the smallest places.

The opening of these school doors was no simple matter, especially because there were none at first. A supplier failed to make delivery of the doors in time for classes to begin. The Board waited a week and then installed some temporary makeshift doors. This allowed the school to open on September 12, 1977. A remarkable accomplishment for a school society of thirty-seven members that was barely 2½ years old. The society was constituted in March of 1975, on an evening when Rev. M. Werkman had been invited to address the members of the Barrhead and Neerlandia congregations in a speech entitled, "Why Reformed Education." At that time there was a Saturday school in operation in Neerlandia and a Thursday evening school in Barrhead. But these congregations are small, together they number about 150 members. It had always seemed impossible to establish a day school therefore. But that evening the brothers and sisters took courage and the young Society, within a period of



Mr. S. Tuininga presents the Bibles on behalf of the Consistory.

two months, adopted a set of constitutional documents, registered as a charitable organization and became incorporated. But it took nearly two years before the Society obtained permission to build a school on land donated by a member. Construction of the school building started on June 14, 1977. Wives and mothers spent a lonely summer, with husbands and sons working from early light to dusk to finish the building in time. Members from congregations as far away as Winnipeg and Edmonton came to help. The building is about 60 feet wide and 80 feet long and contains three classrooms, a library, offices, supply and washrooms, and is designed to allow for future expansion for additional classrooms and a gymnasium. A do-it-yourself school-building into which went the skills, the labour, the love as well as the money of the parents and other supporters.

There was intense activity in other areas too. An Education Committee had been formed in 1976 and early in 1977 it placed ads for two teachers. From among the applicants Mr. Hoekstra and Miss A. Janssen were appointed. Both were formerly on the staff of



A view of the school building.

our school in Smithers. The Society purchased a schoolbus and an Edmonton bookstore was found willing to sell the school most of the textbooks at reduced prices. With a building, teachers, students, schoolbus, books and desks, all the ingredients were present when the school opened that second Monday in September.

About two months later, on November 18, 1977, an official opening ceremony was held at the church building in Neerlandia. The evening was chaired by Mr. P. Werkman, the Society's President. The reading of Psalm 119:1-16 was preceded by the singing of Psalm 150:1 and 3 and followed by opening prayer. In his word of welcome the President drew special attention to the presence of members from the congregations of Edmonton and Smithers and five representatives of the Barrhead County School Committee. The children



Some of the students attending the school.

followed with a rendition of a number of Psalms and Hymns, with some older students providing accompaniment on recorders. Mr. Hoekstra then delivered the keynote address wherein he first of all stressed that this evening was to be one of thankfulness that God made possible what appeared impossible to human calculations. He also sounded a note of caution when he emphasized that the parents remain totally responsible for their children's upbringing. Delivering the children into the hands of teachers and paying the school \$1500.00 a year does not excuse the parents from this responsibility. Sending them to a Reformed school, he went on, does not even provide a guarantee that the children will receive Reformed education. Reformed education may be expected where the parents

MEDITATION

Aliens and Exiles, You Are God's Own People

Beloved, I beseech you as aliens and exiles to abstain from the passions of the flesh that wage war against your soul. Maintain good conduct among the Gentiles, so that in case they speak against you as wrongdoers, they may see your good deeds and glorify God on the day of visitation. Be subject for the Lord's sake to every human institution, whether it be to the emperor as supreme, or to governors as sent by him to punish those who do wrong and praise those who do right. For it is God's will that by doing right you should put to silence the ignorance of foolish men. Live as free men, yet without using your freedom as a pretext for evil; but live as servants of God. Honour all men. Love the brotherhood. Fear God. Honour the emperor.

I Peter 2:11-17

Christians receive their orders from heaven. They are to inherit the earth, but at the moment their LORD and King is yet enthroned in heaven. Many of their fellow world-citizens rebel against the King of kings. They even declare Him non-existent, dead. To them Christians are aliens, who do not fit into the system. What is worse, to them Christians behave as aliens, for they refuse to support the system. Christians claim for themselves a freedom to criticize, using their Bible as a standard for criticism, instead of human reason. These Christians, rather than behaving as aliens, should conform and join the united effort of human reason to bring prosperity to mankind. They should accept their orders here, from men, for there is no one higher than man.

Yet, Christians not only claim that freedom, they have that freedom. Believers are to obey God rather than man, for they are free servants of God.

"Free servants." Is that not a contradiction? You either are free, or you are a servant. You cannot very well be both at the same time. Yet it is true, Christians are free and they are servants. Christians are free, for Jesus Messiah has delivered them from sin and death. He has freed them from the power of the devil and from the A B C of this world. Christians as members of the household of God are free men. Hallelujah! And: they are *servants* of God. Once more, and even more forcefully, Hallelujah!

How easily can an enthusiastic joy in freedom corrupt into using this freedom as a pretext for evil. Then Christians imagine that they do not have to obey civil government under the pretext that this belongs to the world anyway (cf. Romans 13:1-3). Christians might have the misbegotten notion that they have no task to participate as builders in the present society, under the pretext that the Kingdom of God does not come by worldly means. In this manner Christians would not be "maintaining good conduct among the Gentiles" (cf. I Thessalonians 4:9-12; II Thessalonians 2:1-end).

Christians are free men, receiving their orders not from below but from above? Very well, but then Christians must indeed receive them as *orders*. Free men, bound to display, defend, and respect the honour of their heavenly King, that is what Christians are.

These now are their orders: "Honour all men. Love the brotherhood. Fear God. Honour the emperor."

Take note how our LORD mixes society, church, service of the only true God, and obedience to civil government together. Christians have no right to make false distinctions, to piously place God above civil government with the pretext for disobedience. Neither may we place the church above society with the pretext for disrupting society. Christian life comes under the orders of God for the whole of life.

What a blessing that our God, Who knows our hearts, has not only called us "free men," but also His "servants." He has revealed His will to us,

Continued on next page.

become involved with the school and the instruction given there and take great care that, regardless of the subject, it is given according to God's Word. That Word, Mr. Hoekstra said, is the most marvellous pedagogical book there is. It covers a multitude of subjects: laws, human relations, agriculture, health and sex, to mention a few. The things of the world, communism, mohammedanism, evolutionism and all the other -isms will be treated by the teachers from Scripture's all-round point of view. That will prepare the students to be fulltime Christians who, as strangers and sojourners, live a life totally different from, and thus are a light to, the children of the world. Mr. Hoekstra's speech was followed by the presentation of some one hundred slides taken during the construction of the school which recaptured the high



Mr. S. Tuininga admires the school's key.

spirits that had accompanied the hard work of the past summer. When the lights came on again it was the turn of the combined choirs of Barrhead and Neerlandia to make their contribution, under the direction of their conductor *Miss R. Terpsma*. Bearing gifts came Edmonton's School Society President, Dr. P. Van Bostelen, who brought a book and *Mrs. A. Hamoen* with two clocks and a coffee percolator on behalf of the Women's Society. The Board received a gavel from the Principal with instructions to use it exclusively on the heads of Board members and never on teachers. Other presentations followed including that of a school key to *Elder S. Tuininga*, which symbolized the relationship between the school and the spiritual overseers of the Church, charged as they are with seeing to it that the teachers faithfully perform their duties. In turn Mr. Tuininga, for the Consistory and the congregation of Neerlandia, gave Mr. Hoekstra and Miss Janssen a Bible. He then spoke yet some words of thanks to all who had helped with getting the school ready and the meeting was closed after singing and prayer. But the evening went on as everyone went to visit the school for coffee, cookies, cake and conversation, the glad, joyful conversation of brothers and sisters who are experiencing God's blessing upon the loving work of hearts and hands that serve Him in gratitude.

The brief life of this young school

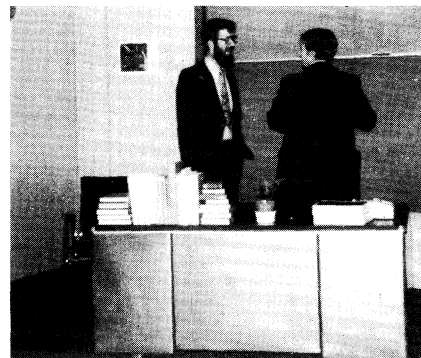

The Principal, Mr. J.J. Hoekstra shows off the sliding blackboards which he designed.

has not been eventful. For personal and very serious reasons Miss Janssen left Neerlandia and temporarily her place was taken by a trio of sisters in the congregation. A more permanent replacement has been found in the person of *Miss J. Kingma*, who served several Ontario schools as supply teacher and has accepted a permanent position with the Fergus/Geulph school for the '78-'79 school year. Mrs. A. Hamoen, who served the Society as secretary for the past few years, had to be hospitalized in Edmonton and much of the material for this article was written by her from her hospital bed. Still, great assurance prevails that the Society did right in establishing this school and already plans are made to hire a third teacher for the next school year. Next year's budget shows that these few members will have to contribute a total of nearly \$48,000.00. There are some peculiar items on this budget. E.g. a "Big-Iron well," at a cost of some \$5000.00 (is the school situated on an iron ore deposit?), and other amounts are mentioned under "crop allowance" and "catwork." There can't be many other schools that have crops and cats, I'm sure.

With their new, but not quite finished school, the members of the Churches in Barrhead and Neerlandia will find that a great burden has been added to their lives. Schools ask the constant attention of so many people for so much of their time, not to speak of the incessant need for money. Yet our burdens grow noticeably lighter when we carry them in faith and fellowship. Neerlandia's Covenant School's very existence is already evidence of that.

And to get back to that old yellow schoolbus with its leaky engine. That was fixed during the Christmas break. Oil's well that ends well. J.J. KUNTZ

that we should put to silence the ignorance of foolish men, *by doing right*. Following the orders of our King we silence them when they speak against us as wrongdoers.

A good example of this is what happened to Jason in the city of Thessalonica. Jason had received the apostle Paul into his home. Jealous Jews, who stumbled over the Rock, tried to drag Paul before the city authorities. When they did not find Paul, they took Jason and hauled him in, crying out, "These men, who have turned the world upside down, have come here also, and Jason has received them; and they are all acting against the decrees of Caesar, saying that there is another king, Jesus" (Acts 17:6, 7).

See, this kind of accusation of foolish men, men bent for death, must never result from the provocation of Christians who use their freedom as a pretext for evil.

Neither should such a false accusation intimidate Christians, causing them to weaken in their rejection of the orders from below. As true servants of God, Christians must continue in the freedom of obeying the orders from above.

Therefore, aliens and exiles, live as free men, but as servants of God; and that in the totality of life.

J. VAN RIETSCHOTEN

King Solomon's Molten Sea

IV. Mathematics, General

4.1 The surprising discovery in section 3.4 that the volume of the Molten Sea was equal to 7,200,000 cubic fingers within 0.2% can be used for further calculations. In previous computations the rather modern value of 3.14 for "pi" (π) was used and one cannot help wondering what numerical value π had in the original design. This of course implies that the dimensions of the sea were not part of the instructions given by the Lord to King David (see section 1.7). From what has been discussed so far, a numerical value for π can be computed. As it is more convenient to use the finger measure, the dimensions in cubits will first be expressed in fingers (fi.). All external and internal dimensions as needed are listed below in (temple) cubits and in fingers. (1 cubit = 28 fi., 1 handbreadth = 4 fi.)

(a) BIBLICAL DIMENSIONS OF THE SEA

	Circumference	Height	Wall-Thickness
	C	H	t
Cubits	30	5	1/7
Fingers	840	140	4

Volume: $v = 2000$ baths

NOTES:

External Radius: $R = C/2\pi$
One bath = 3600 cubic fingers.

(b) CALCULATED DIMENSIONS OF THE SEA

	Internal Height	Internal Radius
	$h = (H-t)$	$r = (R-t)$
Cubits	4 6/7	(R-1/7)
Fingers	136	(R-4)

Volume: $v = 328$ cubic cubits =
7,200,000 cu. fi.

4.2 EQUATIONS FOR v , C AND r

For calculating the volume (v) we need the internal dimensions while the Bible states the length of the external circumference (C). Both can be expressed in algebraic equations and from these a single equation for the internal radius r may be derived. The equations for v and C are as follows:

$$v = \pi r^2 h \quad (i)$$

$$C = 2\pi(r+t) \quad (ii)$$

(Note that $(r+t) = R$; see above.)

If π is considered to be unknown, r is also unknown as a value for π is needed to compute r . Since we have two equations, both unknowns can be evaluated. An easy way to do it is dividing (i) by (ii):

$$\frac{v}{C} = \frac{\pi r^2 h}{2\pi(r+t)} = \frac{r^2 h}{2r+2t}$$

After eliminating π by cancellation we "cross-multiply" and find:

$$2rv+2tv = r^2 h C$$

Rearranging this leads to the following equation:

$$r^2 h C - 2rv - 2tv = 0 \quad (iii)$$

This is a so-called quadratic equation which can be solved. (Please refer to an Algebra textbook or a Handbook of Mathematical tables and formulas.)

The solution is:

$$r = \frac{v}{hC} \left(1 \pm \sqrt{1 + \frac{2htC}{v}} \right) \quad (iv)$$

To find the length of r in fingers we have to insert the following numerical values: $v = 7,200,000$; $h = 136$; $t = 4$ and $C = 840$ as listed in section 4.1. Ignoring the negative root of equation (iv), which leads to the physical impossibility of a negative radius for a circle, it is found that r is equal to 129.931 fi. This is very close to:

$$r = 129 \frac{13}{14} = 129.929 \text{ fi.}$$

It follows that the external radius is equal to:

$$R = (r+t) = 129 \frac{13}{14} + 4 = 133 \frac{13}{14} \text{ fi.}$$

Fig. 4.1 shows a mathematical model of the Molten Sea showing the calculated radii r and R together with the previously derived dimensions ($t = 4$, $h = 136$ and $H = 140$), all in fingers.

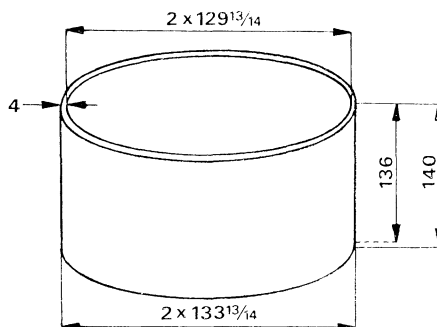

FIG. 4.1 MATHEMATICAL MODEL

4.3 CALCULATION OF "PI"

Above we obtained a numerical value for R and it is a simple matter to calculate π from $C = 2\pi R$. The computation proceeds as follows:

$$\pi = \frac{C}{2R} = \frac{840}{2 \times (133 \frac{13}{14})} = \frac{840 \times 14}{2 \times 1875} = \frac{392}{125} = 3 \frac{17}{125} = 3.136$$

Using $\pi = 3.136$ with $r = 129 \frac{13}{14}$ and $h = 136$, it is found that the volume of the sea is equal to:

$$v = 3.136r^2 h = 7,199,863.9 \text{ cu. fi.}$$

This differs by only 136.1 cu. fi. from the assumed volume of 7,200,000 cu. fi.; less than 0.002%. Or, putting it another way: less than 20 parts per million (20ppm). Dividing 7,199,863.9 by 3600 leads to $v = 1999.96$ baths, very close to 2000. "Pi" may also be calculated directly from (i) and (ii) by means of a quadratic equation. For those readers who like to try the calculation or derive the equation themselves, here it is:

$$\pi = \frac{v}{2ht^2} \left(\frac{htC}{v} + 1 - \sqrt{1 + \frac{2htC}{v}} \right) \quad (v)$$

(Answer:

3.135944, very close to 3.136)

4.4 IS "PI" IN THE BIBLE AFTER ALL?

As shown above, π can be computed from Biblical data. Should we now conclude that the Bible supports a value for π equal to 3.136? Not really, all we may claim is an approximate value and the possibility of its use in an engineering design calculation. Scripture is silent on this and only supplies some dimensions and the volume of the Molten Sea. We do not know the exact rim construction either. Within the limits of the technology of those days, the rim curvature provides ample room for an adjustment to exactly 2000 baths, regardless of the value of π used in the calculations. As mentioned before, King David received instructions from the Lord for building the temple. In section 1.7 it was stated that it seems reasonable to assume that the Lord specified the volume and maybe the shape of the vessel and left the remaining calculations and technical work to His servants. If this is the case, the above "reconstruction" of the mathematical design may represent the original work of Solomon and/or Hiram and their assistants. This in turn means that their value of π is a closer approximation

than the value used by the Babylonians and Egyptians.

It is interesting to compare 3.136 for π with other modern and ancient approximations. Table 7.1 lists several values and their percentage difference with $\pi = 3.1416$.

Source	Value of "Pi"	Difference (%)
Modern *)	3927/1250 = 3.1416	0
Greek	22/7 = 3.1429	(+) 0.04
Solomon	392/125 = 3.1360	(-) 0.18
Babylonian	25/8 = 3.1250	(-) 0.53
Egyptian	256/81 = 3.1605	(+) 0.60
Ancient	3	(-) 4.51

TABLE 4.1

As the table shows, $\pi = 3.136$ is indeed a closer approximation than either the Babylonian or Egyptian value. Not till the time of the Greek Archimedes has a more accurate value for π been recorded in ancient literature as far as known at present.

*) **NOTE:** According to Neugebauer, $\pi = 3.1416$ was first used by a Hindu mathematician in the form 3177/1250¹.

4.5 HOW WAS THE SEA CALCULATED?

Before Greek and Roman times, to the best of our knowledge, there were basically only two systems of Mathematics; the Sumerian/Babylonian and the Egyptian system. Nothing is known about a special Hebrew system but Moses, and probably others too, must have learned Egyptian Mathematics (Acts 7:22; Exodus 38:21-31). In the time of the Kingdoms both systems may have been in use. Moreover we may assume that a master foundry man like Hiram of Tyre would be acquainted with the Sumerian/Babylonian system. It is not known which method or system was used for calculating the Molten Sea. Both the Egyptian and the Babylonian systems would have been suitable. To explain this would take too much space but to give the reader an idea, the internal radius (r) and $\pi = 3.136$ are shown in both systems using modern notation.

As can be seen from these examples the Egyptians worked with unit fractions, 2/3 being the only exception. The Babylonians used the sexagesimal system which they inherited from the Sumerians. We still use the sexagesimal notation for degrees, hours, minutes and seconds. As an example, π can be shown in a similar way as hours, minutes and seconds appear on a modern digital clock or watch. The notation might look like this: 3.8:9:36. The Babylonians had the same problem as we have with the so-called repeating decimals (1/3 = 0.333 . . .) and rounding off. For instance (r) above would have to be rounded off in practical calculations to 1,2,3,4 or more sexagesimal places. The Egyptians did not have this problem as they could express any fraction as a series of unit fractions. Calculations in both systems were probably done with the aid of a counting table with its rows of pebbles, the forerunner of the abacus with rows of beads on stretched wires.

4.6 CONCLUSIONS

It has been shown in the previous sections that the Biblical value of the outside circumference of the sea (30 cubits = 840 fi.) can be computed exactly with $\pi = 3.136$ and $R = 133 \frac{13}{14}$ fingers. Although the volume $v = 7,200,000$ cu. fi. cannot be exactly calculated it is so closely approached that the result is more than satisfactory for all practical purposes. As elegant as the above solutions may be mathematically, 3.136 is certainly not the only value that could have been used for π in the design of the Molten Sea. Even with the Babylonian value of π and a proper choice of radii, a reasonable solution may be obtained as the following example will show. Taking $\pi = 3.125$, $R = 134.25$ fi., $r = 130.25$ fi. and as before $h = 136$ fi., we find $C = 29.97$ cubits (0.1% error) and $v = 2002.8$ baths (0.14% error). These differences are so small that it would be impossible to measure them and for all practical purposes C would be rounded off to 30 cubits and v to 2000 baths.

This shows that other practical

design calculations were indeed possible with quite acceptable results. Therefore we may conclude that if $\pi = 3.136$, $r = 129 \frac{13}{14}$ fi., etc., were used, the calculations were those of a mathematical model (Fig. 4.1). In the layout measurements of the casting mould, adjustments would have to be made for shrinkage of the mould while drying and shrinkage of the bronze while cooling and solidifying.

The mathematics in the previous sections should not be considered essential for the design. We worked our way backwards from the final results to obtain the radii and π . The designers may have arrived at the Biblical value $C = 30$ cubits from a specified 2000 baths volume by trial and error calculations. On the other hand, the Babylonians could solve some quadratic equations^{1, 2}. Therefore the Hebrews and Phoenicians could have been acquainted with the mathematics involved. Further mathematical analysis will show that the above derived radii and $\pi = 3.136$ were in all likelihood used in the design but we cannot be absolutely sure.

A. ZUIDHOF

REFERENCES

- 1 O. Neugebauer, *The Exact Sciences in Antiquity*, pp. 41, 51, 180. Dover Publications, New York, Second Edition, 1969.
- 2 B.L. van der Waerden, *Science Awakening*, pp. 69-71. Wiley, Science Editions, New York, 1963.

Correction

King Solomon's Molten Sea — Third Installment: page 7, Section 3.4, end of first paragraph: the equation for the volume should read:

$$v = 28^3 \pi \left(\frac{C}{2\pi} - r \right)^2 h =$$

$$28^3 \times \pi \left(\frac{30}{2\pi} - \frac{1}{7} \right)^2 \times \frac{46}{7} \text{ cubic fingers (cu. fi.)}$$

OUR COVER

"MAF planes in Sentani; left to right: several Cessnas, the Nomad, an Aero Commander." (Photo courtesy Bram and Joanne Vegter, Irian Jaya.)

Modern	Egyptian	Babylonian
$r = 129 \frac{13}{14}$	$129 + 2/3 + 1/7 + a/14 + 1/21$	$129 + 55/60 + 42/60^2 + 51/60^3 + \dots$
$\pi = 3 \frac{17}{125}$	$3 + 1/9 + 1/45 + 1/375$	$3 + 8/60 + 9/60^2 + 36/60^3$ (exactly)

TABLE 4.2

news medley

A few times already we started far from home, that is: far from the place where we are living. When it comes to the point: wherever the brotherhood is, there is home for us. However, let's for a change start in Toronto.

The Versteeg family has left for the mission field in Irian Jaya and in due time we shall hear of their experiences. It is quite a change, and then not just mentally: the change is there no less climatologically: from the cold and snow into the steaming heat of the tropics. We express the wish that it may not be too hard for them to get used to the climate and that they may receive health and strength from our God to fulfil the task to which they have been sent out.

Meanwhile, to inform you about that, too, the Boersema family was scheduled to arrive in New Westminster and to spend there approximately four weeks, to leave for the Brazilian mission field in the first week of March. The matter of visa was not yet solved, although there was good hope that the visa would be granted for the family. "Indications are that if a visum will be issued it will be only a temporary one." We do not know in how far that would prove to be an impediment, but hopefully not much of one.

Back to Toronto.

The Consistory there decided to discontinue the Dutch services except for the months of June, July and August. That, obviously, is for the sake of visitors from The Netherlands. At least, that's what I gather. "The attendance has gradually decreased. Mostly only about 16-20 people attended of whom about 8 had indeed trouble to follow an English sermon Cassette tapes of Dutch services are available."

The Consistory of Abbotsford, too, decided to discontinue the monthly Dutch service.

It will be so in most instances that those services are attended by fewer and fewer members. Whether we should re-institute them for a few months for the sake of visitors, that is something about which I personally have my grave doubts. If a Consistory wishes to do so, that is wholly up to that Consistory. But I would not be in favour of having them during the summer months to accommodate visitors. If I should be in favour, it would be solely for the members of the Churches here. And of those there are not many who really get nothing out of an English sermon.

There is another point from the Toronto bulletins which I should like to pass on to you. It concerns Andrew Dresser, a son of Dr. Dresser who in Irian Jaya frequently advised and took care of our mission workers there. The Knigge family knows him quite well. I quote now from the bulletin.

Perhaps not all of you know as yet that we received a card from Andrew Dresser. Here it is:

Dear Friends,

Thank you for the radio and the model that you sent me. I've started making the model but haven't finished it yet. The radio is very nice too. I am feeling O.K. and am out of the Hospital. I hope I'll be back in school soon. Thank you for praying for me. Love, Andrew.

From a letter of his Dad we can tell you some more about his condition: Andrew as you know had a second

kidney transplant. But it stopped functioning. There was some hope that it might begin to work again but in the beginning of January he had to go back to the hospital and the kidney had to be removed. He had to be dialyzed five days a week but we hope he will be back to the three times weekly schedule by now. He has a stamp collection, so do put some pretty stamps on (or in) your letters if you write.

He has accepted this further disappointment quite well, though the long period of uncertainty has been hard on all of us Do join us in praying that though our faith be tried (Mal. 3:3), it will be found true and bring only glory to our Lord. We know we can trust the love of the Lord "Who humbled Himself and became obedient unto death" in order that we may have eternal life.

From Toronto we go to Hamilton. I was thinking that it had something to do with our magazine when I read that many volunteered to visit the Clarion Nursing Home. I thought, "Perhaps they have made something ready for retired editors or something like that, and now already many have declared themselves willing to keep them company in their old age." But it appears to be an already existing nursing home which will be visited regularly by members of the Hamilton Church. Hamilton is not the only place where regular visits are brought to nursing homes. It is done in quite a few places and it is highly appreciated by the people residing there. Frequently they do not receive many (if any) visitors and then they are very grateful when members of the Church take the time out to see them more or less regularly. Occasionally cards and letters of thanks are received. That, too, I learned from the Toronto bulletin.

From the report on the Consistory meeting in Hamilton I quote the following passage:

A suggestion is made not to issue envelope sets to non-confessing members who are students. In the discussion it is pointed out that the Committee of Administration is not always aware of the circumstances of each member, and therefore draws one line in issuing sets. It also is pointed out that our young people should serve the Lord, also with their material goods, as soon as possible.

I could not agree more. I know that students are "always poor," at least that's how it was in my student days, except for the few who had rich parents. However, there is practically no student who has no income at all. Many work during the long summer holidays and earn money for their studies and for some luxuries on top of that. The rule is: as soon as one begins to earn, he should give from that first for the Lord. I know of not a few children who, as soon as they started a paper-route, asked for a set of envelopes and every month put one dollar or a dollar fifty into an envelope, depositing it into the receptacle for voluntary contributions. And when their earnings from babysitting, summer jobs, Saturday jobs, etc., increased, their contributions increased too. The parents are to instruct their children in that direction. I do not wish to say that the parents are to check every time how much a child puts into the envelope. It is sufficient when the "general principles" are discussed within the family and when the parents ask once in a while whether the envelope is not forgotten.

When the parents bring up their children in that manner, then it will also be prevented that those children, grown up, spend more per week on unnecessary and foolish actions than on the Church of the Lord. Then it will also be prevented that a special visit will have to be brought by the (al-

ready so busy) office-bearers because the contributions of so-and-so do not even cover what has to be contributed for Mission, Theological College, Cost of Church Federation, and a few other items, let alone what is needed for the local Church life.

We are not through with Hamilton yet.

At a Congregational Meeting the Rev. W. Huizinga delivered an introduction on "Family Worship." In the course of the discussion, the bulletin tells us, he asked, "Why do we find so little singing in our homes?" That was a good question. We could mention a few reasons which, I think, are obvious. There is, in the first place, the fact that not by far every family has a harmonium or a piano. And if there is such an instrument in the home, it is very likely that just one or two members of the family can get some decent sounds out of it. Further, there is the radio which, most of the time, is going all the time; every interference with the radio is frowned upon: "Hey, there is just such an interesting new song on, cut it out, man!" And who can sing at the harmonium or at the piano when the feelings run high during a televised hockey game? Finally, how well-known are our Psalm and Hymns? I admit, we have not had many years as yet in which to study them; besides, they are being changed right now for the definitive edition of our *Book of Praise*; and further, the benefit from learning Psalms at school is beginning to show only gradually. But why is it no longer so that our young people come together on a Sunday evening after the society meeting has been concluded, gather around a harmonium, and sing together until it is time to go home?

Some twenty-five years ago one could be sure of it that, when a group of young people were together in a house on Sunday evening, they asked one whom they knew could play the harmonium or the piano to accompany them. Then they sang, sometimes for an hour or so. Nowadays they rather drive around without purpose, just for the sake of driving and for the sake of being out of the house, it seems.

Here and there I think I discover some hopeful signs. There is a larger number of our young people today that are learning to play an instrument than there were some years ago. Let's keep it up!

Speaking of playing, in Lincoln the Organ was dismantled and taken upstairs, there to be installed to serve the Congregational singing once the auditorium is ready. It cannot be told as yet when that will be. They are working hard on it.

In Smithville, the Women's Society, "God is Our Strength" decided to split into an East-Society and a West-Society. Sometimes — experience teaches me — division along those lines is the preparation for the splitting up of the Congregation into two new Churches. Is this splitting up also such a hopeful sign?

I would rather have skipped Carman, for the only thing which I found worth mentioning is that "there was a complaint about the damage done upstairs to the carpet, especially in the entrance due to cigarette burns. The Congregation is again reminded that there definitely is to be *no smoking* upstairs. We do not want to ban smoking in the whole building yet, although there is merit in it." You said it! More and more Churches have decided that there shall be no smoking in the whole Church building. Some even have extended it to the parking lot! That has nothing to do with an "outer-worldiness" or something like that. It does, I think, in some instances have something to do with the impression which we make on those around us, and that is certainly something which we should take into account.

Our steps go in the direction of Smithers. There appears to be quite something to it there when you put in a bid on something which belongs to the Church. Listen. "Anyone who is interested (in the old organ, vO) can put in a reasonable bid in an envelope and give it to one of the organ committee members. The highest bidder will then be brought before the Consistory, and if they are satisfied with that amount, that member is then the owner of a nice old-fashioned organ, which with proper care may last many a year," (which, I thought, even in spite of proper care, may not last a year. But that was not a very nice thought, I admit.) What would prevent me from putting in a tender would be the fact that I would have to be brought before the Consistory! In order to have my credit-rating established? They don't take things lightly over there, do they?

We did mention something about Abbotsford already. We continue reporting on the Valley now.

In Chilliwack several houses were inspected for possible purchase for a parsonage, but nothing was found that was deemed suitable. As a result, a building committee was appointed.

As general news from the Valley we relate that the brotherhood there is rather enthusiastic about the cutting of a record. The revenue coming from that venture apparently is for the High School. I am looking forward to it, I told you before.

I was also looking forward — remember? — to receiving that all-inclusive address list of the Valley. I shall be waiting in vain. The Langley report revealed the following secret: "The responses and the lack thereof put an end to pursuing this project along the lines envisaged at first." There it goes, out of the window! In a previous *Church News* I read as an argument against such an undertaking that an address list of the whole Valley would be outdated soon, due to the many changes. I could not appreciate that argument at all; it did not make sense to me, for if a *combined* address list is outdated soon that would be caused only by the very same thing by which a *local* address list would be outdated soon: by frequent moving of the membership. If that argument should cut ice, it would not make sense to produce any address list at all.

We started off with some particulars regarding the mission.

Let me close with a piece of information about the very same activity.

The Kuiks are preparing for their furlough which they will enjoy before the Van Spronsens leave the mission field. In that manner there is an experienced worker at the post when one of the two families enjoys a well-deserved rest. "Rest"? Oh, well . . .

Have a good trip, John and Ardis.

vO



Church News

CALLED: to Guelph, Ontario,
REV. C. VAN DAM
of Brampton, Ontario.

DECLINED to Edmonton, Alberta:
REV. S.S. CNOSEN
of Spakenburg, The Netherlands.

Ordination and Installation of Rev. E.J. Tiggelaar

AS PASTOR OF THE CHURCH AT CHILLIWACK, B.C.

"When the sermon is delivered, it is not to give an interesting lecture on a topic of common concern, it is the official message of an ambassador on behalf of his Sender," said Rev. M. Vanderwel as he ministered to the Word of God before the ordination of Chilliwack's first pastor, the Rev. E.J. Tiggelaar, on Sunday, January 22, 1978. The text for his sermon was II Corinthians 5:20 and 21, where Paul

speaks about the manner of the ministry of reconciliation. No longer are animals slaughtered and burned. Instead, the gospel is preached. This preaching comes with the authority of the One Who sent the messenger: Jesus Christ. The message that comes with such authority is a message of God's love: He made Him to be sin, Who knew no sin, and that for our sakes. And the effect of this reconcilia-

tion is that in Him we become the righteousness of God.

Rev. M. Vanderwel, then laying his hand on the head of the new minister, spoke the words of the form: "God our heavenly Father, Who called you to this holy office, enlighten you with His Spirit, strengthen you with His hand, and so govern you in your ministry, that you may be engaged therein properly and fruitfully, to the magnification of His name and the extension of the Kingdom of His Son Jesus Christ."

Thereby ended an eight-year period of vacancy for the Church at Chilliwack, which was instituted on February 1, 1970. Presently the Congregation has 168 members, of which 61 are communicant members.

For his inaugural sermon in the afternoon service, the Rev. E.J. Tiggelaar had chosen the text, Ephesians 2:19-22, about the structure of God's temple, which is the household of God. This is not a static thing; the text is full of activity: building and joining together. So also the congregation of today is growing and being formed as a dwelling place of God in the Spirit. Only the firm foundation is unchangeable, Jesus Christ Himself, the Cornerstone.

On the evening of the following Thursday, the minister and his wife were officially welcomed in a gathering of the Congregation and several guests from the sister churches. The president of the consistory ended his welcome speech by handing over to the new consistory president, a gavel of considerable dimensions.

The delegates from the neighbouring sister churches took turns in mowing the grass away in front of each other's feet. Entertainment was provided mainly by the youth of the Church, among whom the "blijvende jeugd" were highly noticeable. A constant outpouring of coffee and congregational poetry enhanced the festivities. A catechism student, thanking the counsellor, Rev. M. Vanderwel, for the teaching provided during the years of vacancy, spoke on behalf of the consistory, the parents, and "a little bit on behalf of ourselves." Several members of the "Fraser Valley Ministerial Association" kept on giving each other turns to speak. Rev. Tiggelaar put a stop to all this by announcing that catechism would be as usual.

It was an evening much enjoyed by all, in which, as one of the delegates remarked, we could show that there is much "dust for gratitude."



Seated at the "head table": Elder J. DeVos, Mrs. K.F. Huttema, Mrs. E.J. Tiggelaar, Rev. E.J. Tiggelaar and elder K.F. Huttema, president of the consistory.



br. K.F. Huttema presents the gavel to Rev. Tiggelaar.



A group of young students of John Calvin School is waiting for their turn



Part of the audience at the welcome evening. At the table in the foreground the colleagues and their wives. From left to right: Rev. and Mrs. D. VanderBoom, Mrs. M. VanderWel, Mrs. and Rev. M. VanBeveren and Rev. M. VanderWel.



News items are published with a view to their importance for the Reformed Churches. Selection of an item does not necessarily imply agreement with its contents.

NEW CONTACTS?

Wezep, The Netherlands. The Reformed Churches (Liberated, Unaffiliated — Ruiten Verband) of Enschede-Noord and Maassluis have submitted a proposal to the National Convent of these Churches to be held in Wezep, "to seek new contact with the Reformed Churches Liberated (Binnen Verband)." These Churches want to ask the coming General Synod of Groningen for mutual discussions (samen-spreking) on the issues which caused separation in the years 1967-1969.

BAPTIST PROFESSOR DISMISSED

Richmond, Virginia. Prof. Dr. Robert S. Alley, dean of the Theological Faculty of the University of Richmond, has been dismissed from his function. This disciplinary measure was taken against Alley by the American Baptist Churches because he has made "heretical statements." At a recent conference of atheists in the U.S., Dr. Alley



Cardinal Wyszynski "free press . . . ?"

declared that Christ never said of Himself that He was "God's Son," but that statements of this kind in the Gospels are the "private opinions" of the evangelists. Dr. Alley does not consider it reasonable that Christ would have made such statements Himself. Since he feels that the disciplinary action agrees with the best interests of the university, Dr. Alley has not protested the measure.

CARDINAL: FREE PRESS

Warsaw, Poland. Cardinal Stefan Wyszynski, Primate of the Polish Roman Catholic Church, has recently made a plea for more freedom for the ecclesiastical press in his country. "The Church longs for a real Roman Catholic press and the possibility to publish books which can morally edify the people," he said in Warsaw before 2,500 followers. He pledged that the church would cooperate with the civil authorities "if the gospel which is being proclaimed to the nation is not opposed by ungodly propaganda."

BALANCE 1977: MORE THAN 30 MISSIONARIES KILLED

Buenos Aires/Salisbury. More than 30 bishops, priests, and missionaries of various denominations became victims of murder assaults between 1976 and 1977. Most of the killings took place in Rhodesia, El Salvador, and Argentina. The most prominent of the victims were the Archbishop of Brazzaville, Cardinal Emile Biayenda (killed March 1977) and the Anglican Archbishop of Uganda, Dr. Janani Loevoem (killed February 1977). The assaults can mostly be ascribed to political dissension. Missionaries of the Reformed Churches did not encounter any difficulties in this respect.

HUNGARIAN MINISTERS WRITE BILLY GRAHAM

Budapest, Hungary. Various Hungarian ministers have published an "open letter" addressed to Dr. Billy Graham, questioning his recent visit to this country. Basically, the questions ask Dr. Graham if he has indeed met the true religious leaders of the people or has just catered to communist puppets. Some of the questions are: 1) Does Dr. Graham really know who Sandor Palotay is (the man who extended the invitation to Dr. Graham on behalf of the state)? 2) Does Dr. Graham know who Dr. Bartha is (so-called leader of the Reformed Church of Hungary)? In the letter, these two prominent leaders are accused of corruption,

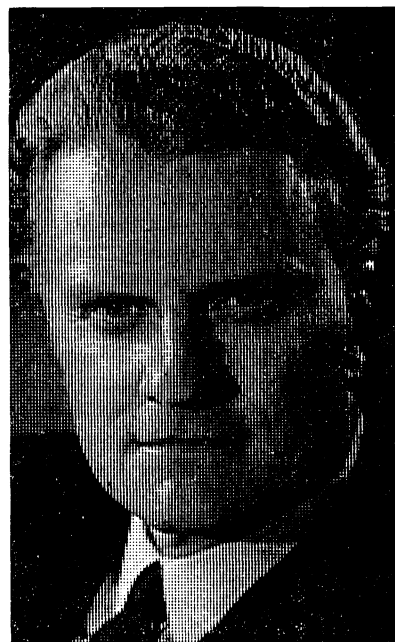

Dr. Billy Graham "taken in . . ."

liquidation of people, and persecution. The ministers fear that Dr. Graham's visit and attitude will cause a wrong impression in the so-called "free world" concerning alleged religious freedom under communist regimes and will result in even stronger measures against religious groups who had no part in Dr. Graham's visit.

BIBLE JAPANESE BESTSELLER

Tokyo, Japan. Since the Japanese Bible Society was organized, almost 100 years ago, 150 million Bibles have been distributed in that country. Yet the number of Christians involves only 1% of the population. Even though the number of Christians does not increase, more and more Bibles are being sold and purchased. The Bible can now be obtained in Japan in 1,800 bookstores.

ANOTHER SYNODICAL "CASE"?

Grand Rapids, USA (RES). After the problems surrounding the teachings of Dr. Wiersinga, the Reformed Churches (Synodical) in The Netherlands seem to have another "case" on their hands. Rev. B. Boelens, of the RCN Church of Castricum, has recently published a book in which he says that the Bible writers sometimes attributed their own ideas to God and that the atonement as satisfaction is a medieval corruption of the Gospel. Various "concerned" leaders have asked the Church to take action against Rev. Boelens.

Cl. STAM



Newsletter 26

Dear Brothers and Sisters,

After having been away for two weeks (one week in Boma to attend a guru-conference, the second week in Kawagit to attend the regular guru-course; but more about these events in our December newsletter), we arrived home again and found the time to sit down and write a little about what took place in November. But first something else. The best news of this year came to us on the 5th of December: "The Rev. and Mrs. Versteeg received their visas, and are planning to arrive in Irian around February 1978!" Undoubtedly you will understand that we are very, very glad and thankful for this, and so were the people here when we told them the news. Five days later, on December 10th we (the ZGK family) also received a telegram from Rev. J.P.D. Groen in The Netherlands. He received his visa as well and will be here, D.V., in the beginning of 1978, and will start working among the Kombay people. That is the area North of Boma.

Now we take a look at November. The first two weeks were spent in Sentani. Unexpectedly we were appointed

to go there and work on our ZGK vacation-house which had been broken into. As you may know, this vacation-house is frequently used by ZGK folks who stay for several weeks in Sentani in order to do some shopping, some other business, or just have their holidays. This time when the thieves entered, they really made it worthwhile: even our fridge had been taken! So we decided to do something about it and reinforced the windows and doors. Since Joanne recently took over the administration of this vacation-house, it followed that the undersigned had automatically become the handy-man (?) for the ZGK house. So on October 31st, Dr. Kees Louwerse, Stefanus (a helper who would do the welding), and I left for Sentani, followed on November 2nd by Mrs. Rennie Louwerse, Joanne, and the kids. The Louwerses were going to Sentani for a three-week break, but Kees spent most of his time helping to fix up the house. During our two-week stay in Sentani, we were able to fix up the house and make it quite a bit stronger. Later, other vacationers will probably do their part to finish up some things. Then we'll just

have to wait and see if our work proves worthwhile.

When we came back, Joanne went right through from Kouh to Manggelum. Because a second flight to Manggelum was planned, Mr. Denis Stuessi (the MAF program manager) came along on the first flight and checked over the Manggelum airstrip site. Everything looked good, and Denis was pleased with what he saw. Later, I talked with him on the radio to receive some further advice, etc. It was too bad that I couldn't be there, but our boat was still in Kouh. So I left Kouh by boat on the 15th and got as far as Kawagit. There I stayed overnight because it was too late to continue on to Manggelum, and the weather didn't look very promising. The next morning I finished the trip.

From November 24th to 29th we enjoyed the company of Miss Elly Nieboer from Kouh. Miss Nieboer supervises the unsubsidized schools in the ZGK area and prepares materials for these schools. She is also actively involved in preparing materials for the Central Bible School in Boma and teaches frequently. Since she has been in Irian for more than fifteen years, you will understand that her help and advice is much appreciated and highly valued. Together we visited the schools in Manggelum, Heyokobun, and Sawagit. Various things came to light which we should change and on which I can keep a closer eye now. For example, the use of a simple picture book along with the Bible stories was not being done as it should. Some teachers told only 2 new stories each week. The other days they reviewed other Bible stories. Because this is also a problem in other villages, we have explained the use of this booklet once again during the last-held guru course in Kawagit. Further, several schools still used books with the old Indonesian spelling, which created some problems. They will have to be changed as soon as possible. The school visits together with Miss Nieboer were very worthwhile, and I got a much better idea of what to look for when visiting the schools.

When Miss Nieboer left again on the 29th, Obed Pekey, our head teacher, went along with her to Kouh. The next day he, with several others, was flown to his own village, close to the Birds Head. He will stay there for a two-month holiday. He plans to get married in that time as well. When he returns we will have to see if he can still return



Clearing the jungle for the new strip in Manggelum.

to Manggelum or if he needs to go to Kawagit.

We plan to start as soon as possible with building a permanent school in Manggelum. When this is finished, hopefully the School Society will "recognize" our school and send one or more teachers here so that we can also provide teaching for the fifth and sixth grades. We hope that the villagers will be diligent in providing beams for this building. Twenty-two beams have been made already, but, as you know, everything goes "pelan pelan" (slowly) here.

The last weeks of November were also taken up with preparation for the guru conference in Boma, held from December 5th to 9th. All gurus from the ZGK area are invited to this conference. I had been requested to deliver a speech on Articles 27-29 of our Belgic Confession, which is about the Catholic Christian Church, and the true and the false church. Just before the conference was held, Rev. Zandbergen from Kawagit came over to Manggelum, and together we went through what I had written down. His visit was much appreciated and very helpful. It is good to be involved in these things, and being a little more at home in the Indonesian language sure helps.

Last month (October) the work on the strip reached a new stage: taking off the layer of rich black earth. It is only 2" or so thick, but that still amounts to a lot of soil on a 30 cm x 600 m surface! Our problem was how to move all that earth. We have three wheelbarrows, but that is not enough. They are also not easy to use on the strip, where a little mud and soft soil bogs them down in no time. So we used a substitute, what we call "gerobak Irian," or, an Irianese wheelbarrow. It is the main nerve of a palm leaf, cut just below the fronds of the leaf, and then "unwrapped" from the tree. The end result looks somewhat like a huge, elongated dustpan, about 2 yards x 2 feet in size. The earth is piled onto this and dragged away. The people use these as garbage pails at their homes in the village; they are easy to get and inexpensive! Via the pictures we sent up with this newsletter you might get a glimpse of them. You will also get an impression of the work which needs to be done to make an airstrip in the jungle.

With kind greetings to all of you,
In His service,

BRAM and JOANNE VEGTER.

Farewell to Rev. H. Versteeg



In the evening of January 16, 1978, many had gathered in the building of the Toronto congregation to say farewell to Rev. and Mrs. Versteeg. After Rev. Mulder had opened the meeting and welcomed those present, br. J. Boot of the Board of Foreign Mission gave a brief review of the happenings which led to the calling of Rev. Knigge and recently of Rev. Versteeg. During his missionary ministry of about 15 years, Rev. Knigge worked most of the time in Butiptiri where a church was instituted. Before leaving Irian Jaya he started preliminary work in Manggelum where br. and sr. Vegter have now been active for two years. Rev. and Mrs. Versteeg hope to join them after a stay of about four weeks in The Netherlands.

Another member of the mission board, sr. C.C. Kuntz then addressed Rev. and Mrs. Versteeg and in a most humorous way displayed a huge envelope which contained a number of items intended to impress on the Versteegs not to forget Canada. The

comical presentation of Miss Kuntz drew much laughter, but at the same time the message was brought home that we should remember the missionary family in our prayers and also write to them.

Several delegates from cooperating churches spoke, and letters received, as well as a telegram, were read by Rev. Mulder. Also present were Dr. K.C. Dresser and his wife of The Evangelical Alliance Mission. Dr. Dresser is very well acquainted with the work of the Reformed Mission in Irian Jaya, where many mission workers, including the Knigge family and the Vegters, benefited from his services. The Dressers had to return to Canada due to illness of their son.

Referring to II Corinthians 2:14, Rev. Mulder spoke a word of farewell to Rev. and Mrs. Versteeg on behalf of the church at Toronto. After Rev. Versteeg had expressed his appreciation for the hospitality and help experienced in Toronto, Rev. Werkman led in prayer and thanksgiving.

A Corner for the Sick

"But the fruit of the Spirit is love, joy, peace, patience, kindness, goodness, faithfulness, gentleness, self control." Galatians 5:22, 23.

This Bible verse gives us a positive view of how we should live fruitful lives, in contrast with verses 19 to 22, where the works of the flesh are named. Then we read verse 24: "And those who belong to Christ Jesus have crucified the flesh with its passions and desires." Do we lead fruitful lives as we evaluate them in the light of verses 22 and 23? Can we be happy and joyful, when we know we fall short in so many ways? Read with me: Question and Answer 56 from Lord's Day 21.

Q.: What do you believe concerning the forgiveness of sins?

A.: That God, for the sake of Christ's satisfaction, will no more remember my sins, neither my sinful nature, against which I have to struggle all my life long; but will graciously grant unto me the righteousness of Christ that I may never come into condemnation.

It is the fruit of the Spirit!

We are righteous before God, on account of Christ's redemptive work. We ourselves are still inclined to all evil, but we may already taste the beginning of eternal bliss, we may experience the beginning

of eternal joy in our hearts, such as eye has not seen nor ear heard, neither entered into the heart of man. This is our confession, based on Scripture! That does not make us careless. It is impossible that those who are implanted into Christ by a true faith should not bring forth fruits of thankfulness! It makes us shout for joy!

*Sing a psalm of joy.
Shout with holy fervour.
All your skills employ;
With your heart and soul
Jacob's God extol.
He is our preserver.*

Psalm 81:1, Book of Praise.

In the last four Clarions we requested you to send cards to several brothers and sisters. The cooperation has been tremendous! We received a thank you letter from Grace Homan and her parents. Grace received over a hundred cards from all over Canada on and after her birthday, and more are still coming every day. It is a feast for her to open the mail, which her mother reads to her.

For the parents it is heartwarming to know that those covenant children are not forgotten. Thank you, brothers and sisters, it is very much appreciated!

A special thank you to the Young People's Society "Shalom" in Cloverdale, B.C.

*Send your requests to:
Mrs. J.K. RIEMERSMA
380 St. Andrew Street E.,
Fergus, Ontario N1M 1R1*

Letters-to-the-Editor

Dear Editor,

I do not for a moment suggest that I am a medical doctor, a lawyer or a professional having studied in the field of "use of body parts after death." I did read with some concern, however, br. Vanbodegom's letter in Volume 27 No. 1 of *Clarion*. By my reaction I do not mean to suggest that the comments made there, or the texts quoted were a deliberate misrepresentation of the facts, since in all likelihood they were written only as a means of stimulating discussion. At least I hope so.

The quotes from Scripture given to indicate that we belong to Christ and that our body is the temple of God and of the Holy Spirit (I Corinthians 3 and 6), should not be taken to mean that our body is worthy of that habitation, and that therefore we cannot donate organs, i.e. cut it up and divide it. Our bodies with all their imperfections could never fulfill as the temple of God, without the forgiveness of sins through

Christ's death. We are God's, however, and therefore we must with our being praise and glorify Him. Furthermore, because we belong to Him in both life and death (Lord's Day 1), we are comforted in the knowledge that He will provide for us and that "neither death, nor life, nor angels — can separate us from the love of God —" (Romans 8:38 and 39). It is His all-encompassing love and care that is emphasized here, not the specific fact that our physical body belongs to Him, although of course it does.

There is no question in my mind that we place too much emphasis on the welfare of our temporal body. The fuss about the body of a deceased is largely misdirected. Although it is difficult to give up our loved ones, the excessive concern about appearance etc. before burial is basically an inability to free ourselves of earthly things. After all, we are told in Scripture that we are from dust and to dust we will return. When Christ comes again to judge, He will take those that are His to Him, to reign with Him on the new earth. All

things will be new and free of the effects of sin.

God has given scientific knowledge. With it He enables the use of medicine to restore health and correct malfunction of our bodies. I am convinced that the use of donated organs and use of knowledge gained from donated bodies is part of this healing ability that God has granted. The decision to grant consent to the use of body organs after death must be a personal decision, obviously in consultation with family members. However, I do not think that God forbids the granting of such consent.

Yours sincerely,
J. VANDERSTOEP,
Surrey, B.C.

FOR THE READER'S INFORMATION

This issue of *Clarion* was mailed from Winnipeg Central Post Office on February 18, 1978.

Food: Facts and Fallacies

NUTRITION AND CARDIOVASCULAR DISEASE

A news story under the heading, "Ottawa prepares diet sheet," appeared in one of our local dailies. The story was from *Canadian Press* and may well have appeared in other papers across the country. The substance of the report was that the Department of Health and Welfare is putting together a programme aimed at encouraging Canadians to improve their eating habits. This intention was announced at the occasion of a federal-provincial food strategy conference. Much could be written about all that surrounds this particular conference, but this had better wait till another time.

The purpose of writing about this under the title of "Nutrition and Cardiovascular Disease" is that the programme announced by the Department of Health and Welfare is based largely on the recommendations of a committee of experts' report on diet and cardiovascular disease. When during the years of 1971-73 Nutrition Canada was underway, extensive information was obtained on the nutritional status of Canadians. The single, most important finding was that a very great proportion of Canadians were obese, that is, heavier than is considered normal or desirable for their particular physical size. Most of us have at one time or another felt the discomfort of too much weight, but all too few are fully aware of the health implications of it.

With the exception of certain medical causes, obesity is the result of improper dietary habits. Usually the root of the problem is too much of all foods and beverages or else an incorrectly balanced consumption of the many different foodstuffs available.

Canadians enjoy one of the highest standards of living in the world and life expectancy from birth is 69.3 years for men and 76 for women, which is similar to that of other Western nations and higher than that of less industrialized nations. However, in Canada, 50% of all deaths can be attributed to cardiovascular disease, and 80% of cardiovascular deaths are caused by atherosclerosis, or hardening of the arteries,

causing heart attacks, strokes, etc. This condition occurs not only in old age, but also affects significant numbers of Canadians of middle age. In fact, about one-third of all deaths among people under age 65 is attributed to atherosclerosis.

There are several well recognized conditions, or risk factors, which predispose an individual to premature atherosclerosis. The conditions providing the greatest risk, not necessarily in order of importance, are hyperlipoproteinemia, which is an elevation of blood cholesterol and/or lipids, diabetes, high blood pressure, and smoking. Other factors which may be important, but which are at present still somewhat controversial, include obesity, physical inactivity, and stress. Scientific evidence indicates that the presence of more than one of these factors in the same individual greatly increases the risk.

On the basis of Nutrition Canada, suggesting improper eating habits, and on the basis of considerable evidence pointing to an association between diet, increased blood lipids or fats, and the clinical manifestations of atherosclerosis, the Federal Government struck the committee of experts mentioned earlier. This committee, chaired by Dr. Mustard of McMaster University, examined all available information and in its report to the Minister of Health and Welfare made certain recommendations. Among these are some definite health measures, such as, avoiding overeating and smoking, and having regular medical examinations. These should include measurement of blood cholesterol, triglycerides, sugar, and blood pressure. If any of these are found to be elevated, investigation and treatment should be carried out by a physician.

In addition to these specific health measures, Canadians are also advised to practise moderation in the use of foods and beverages which tend to elevate blood fats and to avoid foods which provide calories without essential vitamins and minerals. The rationale for these recommendations is much too lengthy to discuss here, however, subsequent articles could look at some of these things in more detail.

The recommendations are as follows:

a) *The consumption of a nutritionally adequate diet, as outlined in Canada's Food Guide.*

This Guide suggests specific quantities of the basic food groups so as to ensure adequate intakes of all the required nutrients. Without some further discussion as to the rationale of this food variety, the Food Guide might seem a little extravagant. Again, an article on this item might be worthwhile.

b) *A reduction in calories from fat to 35% of total calories, with emphasis on an increase in the intake of linoleic acid.*

An obvious means of reducing fat intake is to choose leaner cuts of meat and to discard fat which cooks out of meat. This might seem a tremendous waste, especially to those among us who experienced the difficult times of depression and war. However, it should be recognized that today our food intake generally exceeds our energy requirement, and the most efficient way of reducing is to avoid fat, since it is the most concentrated source of food energy. Avoiding excessive use of high fat dairy products and the use of foods which are deep-fried are other means of decreasing fat intake.

The other reason for limiting fat is because of the role it plays in elevating blood lipids. Saturated animal fats are particularly noted for this, and therefore, when fats or oils are to be used, vegetable oils high in unsaturated fatty acid content should be used.

c) *The consumption of a diet which emphasizes whole grain products and fruits and vegetables, and minimizes alcohol, salt, and refined sugars.*

The basis of this recommendation is again to control caloric intake but also to limit the intake of food items that contain little else besides calories. Since food intake is regulated by need for calories or energy, a satisfaction of this need by empty-calorie foods can lead to less than adequate intakes of vitamins and minerals. Consumption of such high caloric snack foods, such as, potato chips, other deep-fried snacks, chocolate and other candies, soft drinks, and alcohol is not advisable.

d) *The prevention and control of obesity through reducing excess consumption of calories and increasing physical activity.*

To prevent obesity one can reduce caloric intake or else increase
Continued on page 93.

our little magazine

(Just a reminder, Busy Beavers: if you, or your older brother or sister Busy Beavers feel you are "too old" for our club, and for birthday wishes, PLEASE drop me a line. Let me know, all right?)



From the Mailbox

Dear Busy Beavers,

Today I got two letters in the mail that didn't match very well, I don't think. Let's see what you think about it. First, I got this letter from our Busy Beaver "down under" in Australia. Just listen to what she wrote,

"At the moment we are having our summer holidays, and they are rather warm. Here in Albany it isn't so bad but in Perth it is very hot. Today it was 44°C (113°F) for a period of five hours there! It is rather muggy and humid here. Last night it thundered and it is still thundering; not much, but still enough to notice it . . ."

We went swimming this morning at Middleton Beach. The waves were beautiful, nice and big . . ."

That was from the Busy Beaver in Australia. And then, would you believe, another Busy Beaver, this one from Ontario, sent in this poem:

Winter

Winter is a time of snow,
Sometimes it snows and sometimes it blows.
And it gets cold, you know.

Winter is a lot of fun,
For you can laugh and play and run,
Toboggans and sleighs and skates and skis,
We are lucky to have all these.

Up the hill and down hill, go, go, go.
Over the ice that glitters and glows,
Across big white fields.
WHEW! I would like a nice hot meal.

by Busy Beaver, *Marcella Veenman*.

Now then, Busy Beavers, you tell me, do YOU think those two letters matched very well?

Let's first wish all our Busy Beavers celebrating March birthdays a very happy day together with their family and friends. Many happy returns of the day to all of you! May God guide and keep you in the year ahead.

Joanne De Groot	March 2	Margaret	March 17
Lorraine Heres	2	Tenhage	
Stephanie Louwerse	2	Pat Kamstra	20
Janet Veenendaal	2	Henriette Bosscher	21
Brian Hendricks	3	Jollette Moeliker	21
Lyndon Kok	4	Marjorie Smouter	22
Simone Datema	8	Debbie Aikema	23
Joanne Oostdijk	9	Heather Bergsma	24
Jo-Anne Vander Ploeg	9	Cor Bultena	27
Angela Wiersema	9	Charles Slaa	27
Hilda Jongsma	11	Carolyn Irene	29
Marsha Oosterhoff	12	Hoeksema	
Jacqueline Riemersma	13	Henrietta Beukema	31
Joanne Doekes	15	Mary Van Woudenberg	31
Michael Bosch	17	Jane Wiegers	31

Welcome to the Busy Beaver Club, *Karen Gay Barendregt*! We hope you will really enjoy being a Busy Beaver and will join in all our Busy Beaver activities. Your school did very well on your walk-a-thon, didn't they? Write again soon, Karen.

And a big welcome to you too, *Lorinda Barendregt*. We are happy to have you join us. Thank you for the nice poem and picture, Lorinda. I'm sure the Busy Beavers will enjoy them! Bye for now.

Welcome to the Busy Beaver Club, *Arlene Buist*. We hope you, too, will join in all our Busy Beaver activities and really enjoy being a Busy Beaver. Bye now, Arlene. Drop me a line again soon.

Thank you very much, *Anna 't Hart* for your letter. It was really nice to hear from you again. You're right, it was always special having a Busy Beaver "down under," and I do hope you will keep in touch. I'm glad you're enjoying your holidays and best wishes for your new school term when it starts. Bye for now.

Hello *Mary Vande Burgt*. Thank you very much for a nice long, chatty letter. Did you like the wedding, Mary? And how did your choir performance go at the dinner? I think your sister must have been very happy with the jumper and slippers you crocheted for her baby. Thank you, too, for the contribution to our Birthday Fund Project, Mary. I hope many Busy Beavers will follow your good example!

Congratulations on your new baby sister, *Cindy Linde*. You did very well on your quizzes. Good for you! I hope your weather has improved by now, Cindy. And thank you, too, for your contribution to our PROJECT.

Thank you for your nice chatty note, *Greta Bosscher*. I liked the little decoration you put on it! Do you make them more often? That will be fun, having your grandparents over. I'm glad you want to help with our PROJECT, too, Greta. Let's hope all the Busy Beavers will.

Hello, *Robert Feenstra*. It was nice to hear from you again. You really scrambled those letters, didn't you? Thank you for sending in the quiz, Robert. Write again soon.

How is your crocheting coming, *Sylvia Jans*? I'm so curious what you are making, and how it's coming along! Be sure to drop me a line when you're finished, and tell me about it. Sylvia, I don't know what happened to your dollar. I hope you do. I did not get it in your letter. Bye for now.

I'm glad you had such nice Christmas holidays, *Karen Wiegers*. And now you'll soon be having holidays again! Thank you for the poem, Karen. We'll share it with the other Busy Beavers, come spring.

Thank you for the Book Look and the poem, *Henrietta Stieva*. Shall I save the poem for the next contest, seeing this one was finished? Thank you for your good wishes, Henrietta. And write again soon.

Congratulations on your new cousin, *Elaine Hamoen*. No wonder everyone was very happy. How are things at school, Elaine? And does your new arrangement for doing the quizzes work out better?

QUIZ TIME

Thank you for this word search puzzle, *Annette Van Andel*. Have fun doing it, Busy Beavers!

Things That Are In Church.

	B	I	B	L	E	S	A	B	Z	X
Bibles	B	M	P	S	A	L	T	E	R	S
bulletin	U	T	I	P	L	U	P	N	Z	Y
carpet	L	M	O	N	E	Y	B	A	G	S
deacons	L	T	H	G	I	L	J	G	F	H
elders	E	L	D	E	R	S	R	R	M	S
light	T	E	P	R	A	C	T	O	Y	W
minister	I	O	S	N	O	C	A	E	D	E
money bags	N	U	R	S	E	R	Y	Y	R	P
nursery										
organ										
pews										
pulpit										
psalters										

How many Bible names could you find in last time's Puzzle Circle?

Let's start at the top and go clockwise. Here they are:

Solomon, Nahum, Moses, Samuel, Levi, Isaiah, Ahab, Habakkuk, Kings.

And here are the answers to "I Am."

1. (d); 2. (g); 3. (h); 4. (l); 5. (j); 6. (c); 7. (f); 8. (i); 9. (k); 10. (e); 11. (b); 12. (a)

There! How did you do? All right? Good! Just a few wrong? Try again next time!

Just about time to close, Busy Beavers. We've got a fine start with our PROJECT — let's keep up the good work! Have you sent in your contribution?

Bye for now.

With love from your,
Aunt Betty.



FOOD — FACTS AND FALLACIES — Continued

physical activity to use up the excess calories. A combination of these two is preferable, since physical inactivity is another risk factor in cardiovascular disease. The degree of physical activity is undoubtedly very important as well. To say that everyone should engage in strenuous sport or long distance running, is, of course, an oversimplification. One's physical condition must permit such activity.

The recommendations are general, of course, and do not apply to infants, to patients on therapeutic diets, or to special segments of the population such as pregnant women, nursing mothers, the elderly, or the infirm. Some special considerations are called for here.

You will in all likelihood be confronted again by the material of this article. Since February is Heart month, the Federal Government has chosen this month to promote these preventative programs. Other media will present articles and ads on this subject and you will probably receive some material with your pension or family allowance cheques.

No doubt certain questions will have been raised by this brief discussion, such as, which fats are good, which are bad; which foods are high in cholesterol; etc. Future articles can deal with some of these topics.

J. VANDERSTOEP

Our Covenant God has given in our trust another son:
MAYNARD THEODORE
our sixth child.
A brother for: *Henry, John, Derek, Jean, Geraldine*
Thankful parents:
Bert and Theresa Lanting
Psalm 127.
R.R. 2,
Florence, Ontario NOP 1R0.

With thankfulness to the Lord, Who made everything well, we announce the birth of our son:
MARK CHRISTOPHER
A brother for: *Agnes*
Herman and Yke Timmerman
(nee Crossen)
February 3, 1978.
9 Islington Avenue,
Guelph, Ontario N1E 1B2.

With great joy and thankfulness to the Lord, we announce the birth of our son:
MATTHEW CORNELIUS
Kees and Bonnie Veenman.
A brother for: *Bryan and Jennifer*
January 28, 1978.
180 Mercer Street,
Chatham, Ontario.

With joy and thankfulness to our Father in heaven, Who has made everything well, we announce the birth of our first child; a son:
SELBY LAYNE
Born December 10, 1977.
John and Alice Bareman
Box 754,
Grassy Lake, Alberta T0K 0Z0.

With joy and thankfulness to the Lord, the giver of life, we announce the birth of our daughter:
RACHEL JOAN
Born January 27, 1978.
A sister for: *Norma, Bill, Philip, Michael and Cynthia.*
Peter and Reka Vanderpol
8591 - 150 Street,
Surrey, B.C. V3S 5A3.

With thankfulness to God, the Creator of Life, and with great gladness do we announce the birth of our daughter:
FIONA ANN
A sister for: *Kevin.*
On December 15, 1977.
Hayo and Jenny Jager
(nee Nyenhuis)
1284 Nottingham Avenue,
Burlington, Ontario L7P 2R8.

1933 - March 3 - 1978

It is with thankfulness to our Lord and Saviour, the giver of life, that we may celebrate with our parents and grandparents their forty-fifth Wedding Anniversary.

JAKOB BUIKEMA
and
MARTHA B. BUIKEMA (nee Faber)

Their thankful children and grandchildren:

Oakville, Ont.: Ken and Christine Buikema
*Henrietta, Marti and Andy,
Ingrid, Sonja*

Burlington, Ont.: John and Ann Buikema
*Jim, John, Anne, Charles,
Gilbert, Marcy, Peter*

Burlington, Ont.: Gus and Binie Buist
James, Marcia, Rita, Richard

Orangeville, Ont.: Gary and Alice Veenman
*Marcella, Jody, Mark,
Jocelyn*

Burlington, Ont.: Bert and Eve Buikema
Lori and Jackie

937 Longdrive, Burlington, Ontario.

Reception on March 3, 1978, in the church building of the Canadian Reformed Church of Burlington West from 3:00 to 5:00 p.m., 1203 Highway #5, Burlington, Ontario.

1953 - 1978

With thankfulness to the LORD we hope to celebrate our parents' and grandparents' 25th Wedding Anniversary on March 12, 1978, D.V.

JOHN SCHULENBERG
and
RITA SCHULENBERG (nee VanderVeen)

Stoney Creek, Ont.: Jenny and Steve Mandula
Smithville, Ont.: Alice and Arno Linde
Merika

Smithville, Ont.: Yolanda, Arlene, Allan, Terri-Lynn

Open house on March 13, 1978, from 2:00 p.m. - 4:00 p.m. and 7:00 p.m. - 9:00 p.m., at home.

Station Street, Smithville, Ontario L0R 2A0.

Soli Deo Gloria

On March 1, 1978, we hope to celebrate the 50th Wedding Anniversary of our beloved Parents, Grand and Great Grandparents:

GEORGE and HILDA WIEGERS (nee Bontkes)

Henry and Ruly Wieringa
Bob and Coby Wiegiers
John and Liz Winkel
John and Rie Wiegiers
Herman and Jenny Stel
Henry and Ann Super

29 Grandchildren

8 Great Grandchildren

The Canadian Reformed School Society of Surrey, B.C., invites applications for the position of:

ELEMENTARY GRADE TEACHER

Duties to commence September 1978.

For information contact:

Mr. S. VanderPloeg, Principal
809 - 14 Street,
New Westminster, B.C.

Applications will be received by the board:

c/o W. Dam,
19671 - 46A Avenue,
Langley, B.C. V3A 5G3

The Board of the John Calvin School at Burlington, Ontario, invites applications for the position of:

TEACHER

for the 1977/78 school year.

Please direct your inquiries, and letters of application stating qualifications and experience to the principal,

Mr. H.E. Hoogstra,
c/o 607 Dynes Road,
Burlington, Ontario L7N 2V4
Phone: (416) 634-8015 (school);
(416) 637-9076 (res.)

The Lord took unto Himself, after a short illness, His child, our beloved mother, grandmother and great-grandmother:

JANTIEN KEUN

at the age of 77 years.

Predeceased by her husband, Jacob Kobes, on January 14, 1970.

Psalm 89:7

Kelmscott, W. Australia: J. Kobes
R. Kobes - Linde
Abbotsford, B.C.: S. Kobes
T. Kobes - Poll
Clearbrook, B.C.: K. Kobes
F. Kobes - Poll
Surrey, B.C.: A. Kobes
G. Kobes - Biesbroek
Surrey, B.C.: R. Biesbroek - Kobes
K. Biesbroek
Lethbridge, Alta.: T. Daniels - Kobes
D. Daniels
Sardis, B.C.: H. Kobes
M. Kobes - Veldman
Matsqui, B.C.: J. Jongs - Kobes
N. Jongs
Grandchildren and
Great Grandchildren.

February 8, 1978.

41282 South Sumas Road, Sardis, B.C. V0X 1Y0.

The Canadian Reformed School Society of London and District requires a:

PRIMARY TEACHER

to teach grades 1, 2, 3 and 4.

Duties to commence on September 5, 1978. Please submit enquiries to:

Mrs. J. Lindhout,
875 Waterloo Street,
London, Ontario N6A 3W7

The Eben-Ezer Canadian Reformed School Society in Chatham is in need of a:

TEACHER

for the elementary grades and:

1 TEACHER

for grade nine.

Duties to commence in September 1978.

For information contact:

Mr. A. vanOverbeeke, Principal,
347 McNaughton Avenue East,
Chatham, Ontario N7L 2H1
Phone: (519) 354-5161

Applications to be sent to:

The Education Committee, c/o Mrs. F. Westrik,
69 Thornhill Crescent,
Chatham, Ontario N7L 4M2
Phone: (519) 351-1982

We will need a:

TEACHER

for the grades 5 and 6, starting September 1978.

The Board of the Canadian Reformed School Society of Carman, Manitoba Incorporated, invites applications for this position. Please direct inquiries and/or applications to the secretary:

Mr. Fred De Wit
Box 27, Carman, Manitoba R0G 0J0
Phone: 1 - 204 - 745-3270

The Board of the "Ebenezer" Canadian Reformed School of Smithers, B.C., invites applications for a:

TEACHER

for grades 3 and 4

Duties to start September 1978.

For information contact:

Mr. M. Moeliker, Principal,
Box 2439, Smithers, B.C. V0J 2N0
Phone: (604) 847-2805 (Home) or
(604) 847-3492 (School).

Send applications to the Secretary of the Board:

Henry Penninga,
Box 2439,
Smithers, B.C. V0J 2N0

The Board of the Canadian Reformed High Schools in the Fraser Valley invites applications for the positions of:

PRINCIPAL and TEACHERS

The school will, D.V., commence operations in September 1978 with a staff of 7 full-time teachers and a principal.

Student enrollment is expected to be 130 in the first year.

Applications and/or inquiries should be directed to the secretary:

Mr. J. Schouten,
9771 - 124A Street, Surrey, B.C. V3V 4W2
Phone: 1 - 604 - 588-4556

Coaldale Christian School, located in the heart of the sunny South of Alberta, is in need of a:

Junior High and/or Intermediate

TEACHER

for the 1978-1979 school term.

We Offer: — modern facilities
— attractive salary schedule and fringe benefits
— healthy climate

Please forward applications to:

Mr. I. Veurink
Box 1479,
Coaldale, Alberta T0K 0L0
Phone: (403) 732-4907

Feel free to write for more information to the Principal:

Mr. Wm. Van Spronsen
Box 1479,
Coaldale, Alberta T0K 0L0
Phone: (403) 345-4055 (School)
(403) 345-4063 (Residence)

Timothy Canadian Reformed School Society, Hamilton, Ontario, is in need of:

A TEACHER

for the coming school year.

For information contact the Principal:

Miss J. Kingma,
80 Pritchard Road,
Group Box 7, Hamilton, Ontario L8V 4L3
Phone: (416) 388-4747 (home) or,
(416) 385-3953 (school)

Send applications to the secretary of the Education Committee:

Mrs. T. Ludwig,
1250 Limeridge Road East,
Unit 19, Hamilton, Ontario L8W 1P1.

Now is the time to order your Study Material for the coming society year.

The Book of Haggai — <i>A.B. Roukema</i>	\$0.60
The Book of Revelation (Chapters 1-11) — <i>L. Selles</i>	\$1.50
The Book of Revelation (Chapters 12-22) — <i>L. Selles</i>	\$2.00
The Church According to the Reformed Confession — <i>G. Visee</i>	\$0.90
Epistle to the Colossians — <i>W.G. de Vries</i>	\$0.60
The Epistle to the Hebrews — <i>L. Selles</i>	\$2.60
Liturgy of God's Covenant — <i>G. van Rongen</i>	\$1.00
Purim (Esther) — <i>J.A. Wiskerke</i>	\$0.85
Take Your Stand (Our Christian Calling in Every-Day Life) — <i>P. van Gorp et al</i>	\$0.90
To the Praise of His Glory (Canons of Dort) — <i>J. Faber et al</i>	\$1.25
We Believe I (Belgic Confession, Articles 1-17) — <i>J.A. Vink</i>	\$0.90
We Believe II (Belgic Confession, Articles 18-37) — <i>J.A. Vink</i>	\$1.25
The Words of the Divine Great King (Deuteronomy) — <i>G. van Rongen</i>	\$1.50
You ... God's Child (Baptism) — <i>P.C. van Wijk</i>	\$0.55
You ... His Guest (Lord's Supper) — <i>P.C. van Wijk</i>	\$0.55
Young People's History of the Church I — <i>W. Meyer</i>	\$2.90
Young People's History of the Church II — <i>W. Meyer</i>	\$2.90
Young People's History of the Church III — <i>W. Meyer</i>	\$2.90
Your Ecumenical Task — <i>K. Schilder</i>	\$0.70
IN DUTCH	
Autarkie of Subsidie — <i>A.J. Verbrugh et al</i>	\$1.25

NOW AVAILABLE:

Galatians — <i>M.J.C. Blok</i>	\$1.25
Outlines on the Epistle to the Galatians. Translated from the Dutch. Bibliography of material in the English language has been added.	

A 10% discount will be given on orders of 10 or more copies of any outline.
Postage Extra.

All orders for Outlines and Books should be sent to:

PREMIER PRINTING LTD.

1249 PLESSIS ROAD, WINNIPEG, MANITOBA R2C 3L9 — TELEPHONE: 222-5218

All Outlines and Books are also Available at:

THE FAMILY CHRISTIAN BOOK STORE
BURLINGTON AND HAMILTON